

4AC13

PRODUCT SPECIFICATIONS

13 SEER SPLIT SYSTEM AIR CONDITIONER

FORM NO. 4AC13-100 (10/2014)

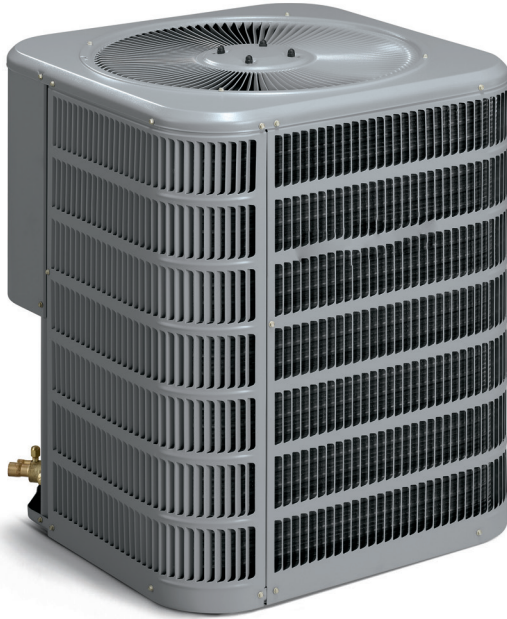

- R410a Refrigerant
- High-quality condenser coil with copper tubing and enhanced louvered fin for maximum heat transfer capacity
- Top discharge directs hot air away from living area and shrubbery
- All units factory run tested
- Available with louvered panel or wire guard coil protection
- Easy access to electrical panels
- Corner mounted service valves for easy hook-up and service
- Liquid line filter drier shipped loose
- Charged for 15 feet of interconnecting tubing
- All units ETL and ETL certified and AHRI certified

WARRANTY

10 year limited warranty on compressor, 10 year limited warranty on all parts, extended warranty available*

**Warranty provides for a total of 10 years of limited warranty coverage (Standard 5-year limited parts warranty plus an additional 5-year limited extended parts warranty). Warranty must be registered online within 60 days of installation to qualify for 10-year coverage. Unregistered equipment defaults to 5-year coverage. Lifetime limited heat exchanger warranty applies to registered equipment only (Standard 20 years with no online registration). See full warranty at www.alliedair.com for terms, conditions and exclusions.*



Model Number Guide

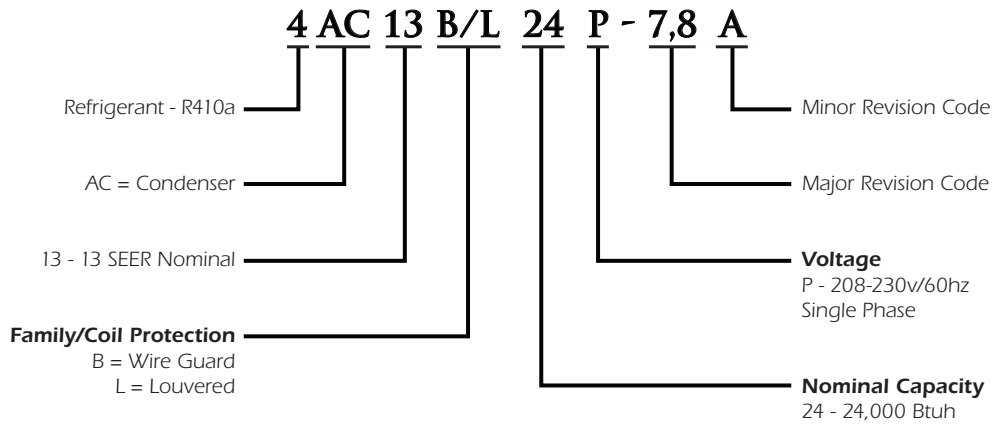

Electrical and Physical Data

Model	Voltage/ Hz/ Phase	Voltage Range	Min. Circuit (Amps)	Max. Fuse (Amps) †	Compressor		Fan Motor			Refrig. Charge (oz.) † †	Weight (lbs.)	
					Rated Load (Amps)	Locked Rotor (Amps)	Full Load (Amps)	Rated HP	Nom. RPM		Wire Guard	Louvered
4AC13*18P-7, 8	208-230/60/1	197-253	10.9	15	8.1	39	0.7	1/10	1010	62	125	136
4AC13*24P-7, 8	208-230/60/1	197-253	14.1	20	10.7	53	0.7	1/10	1010	63	126	137
4AC13*30P-7, 8	208-230/60/1	197-253	15.6	25	11.6	59	1.1	1/5	1090	82	139	147
4AC13*36P-7, 8	208-230/60/1	197-253	20.1	35	15.2	70	1.1	1/5	1090	84	141	149
4AC13*42P-7, 8	208-230/60/1	197-253	28.1	45	21.1	90	1.7	1/4	825	104	184	194
4AC13*48P-7, 8	208-230/60/1	197-253	31.9	50	24.1	100	1.7	1/4	825	124	181	192
4AC13*60P-7, 8	208-230/60/1	197-253	29.4	60	22.1	120	1.7	1/4	830	144	194	205

† Overcurrent protection device
 † † Factory charge adequate for 15 feet of line set. Adjust per Installation Instructions.
 * = B or L B = Wire Guard L = Louvered

Unit Dimensions & Sound Ratings

Note: Dimensions listed are unit sizes w/o packaging

Model	Dimensions			Sound Ratings (dBa)
	A - width (in.)	B - depth (in.)	C - height (in.)	
4AC13*18P-7, 8	24.25	24.25	25	74
4AC13*24P-7, 8	24.25	24.25	25	74
4AC13*30P-7, 8	24.25	24.25	29	74
4AC13*36P-7, 8	24.25	24.25	29	74
4AC13*42P-7, 8	28.25	28.25	29	79
4AC13*48P-7, 8	28.25	28.25	33	79
4AC13*60P-7, 8	28.25	28.25	29	80

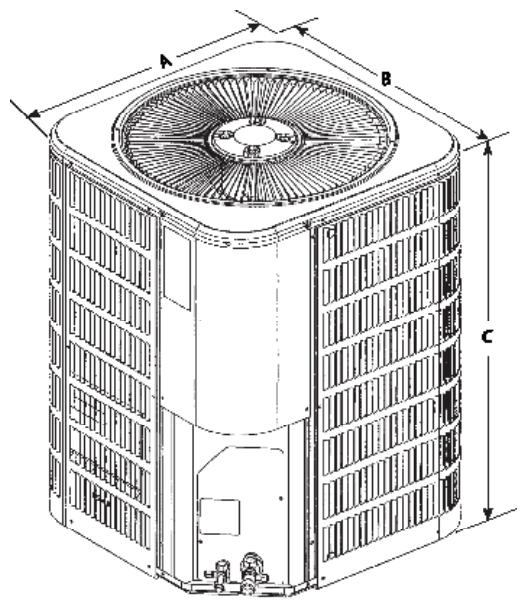

* = B or L B = Wire Guard L = Louvered

Cooling Performance with Evaporator Coils

Outdoor Model	Indoor Model	SEER	EER	Rated AHRI Capacity ¹	Rated Sensible Capacity	CFM	Refrigerant Connection				Refrigerant Line Size		Indoor Metering Device	
	Evaporator Coil ³ or Air Handler ³						Outdoor		Indoor		Suction	Liquid	Piston ²	TXV
							Suction	Liquid	Suction	Liquid				
4AC13*18P-7, 8	E(C,H,M,U)1P23(A,B)+TDR	13.00	11.00	17600	12800	650	5/8	3/8	3/4	3/8	5/8 ⁵	3/8 or 1/4 ⁴	0.053	A4TXV01
	E(C,M,U)1P24(A,B)+TDR	13.00	11.00	17600	12800	650	5/8	3/8	3/4	3/8	5/8 ⁵	3/8 or 1/4 ⁴	0.053	A4TXV01
	E(C,H,M,U)1P29A+TDR	13.00	11.00	17600	12800	650	5/8	3/8	3/4	3/8	5/8 ⁵	3/8 or 1/4 ⁴	0.053	A4TXV01
4AC13*24P-7, 8	E(C,H,M,U)1P23(A,B)+TDR	13.00	11.00	22800	16800	800	5/8	3/8	3/4	3/8	5/8 ⁵	3/8 or 1/4 ⁴	0.057	A4TXV01
	E(C,M,U)1P24(A,B)+TDR	13.00	11.00	22800	16800	800	5/8	3/8	3/4	3/8	5/8 ⁵	3/8 or 1/4 ⁴	0.057	A4TXV01
	E(C,H,M,U)1P29A+TDR	13.00	11.00	22800	16800	800	5/8	3/8	3/4	3/8	5/8 ⁵	3/8 or 1/4 ⁴	0.057	A4TXV01
	E(C,M,U)1P30(A,B)+TDR	13.00	11.00	22800	16800	800	5/8	3/8	3/4	3/8	5/8 ⁵	3/8 or 1/4 ⁴	0.057	A4TXV01
	E(C,H,M,U)1P36(A,B,C)+TDR	13.00	11.00	22800	16800	800	5/8	3/8	3/4	3/8	5/8 ⁵	3/8 or 1/4 ⁴	0.057	A4TXV01
4AC13*30P-7, 8	E(C,H,M,U)1P23(A,B)+TDR	13.00	11.00	28000	20400	1000	3/4	3/8	3/4	3/8	3/4	3/8	0.063	A4TXV01
	E(C,M,U)1P24(A,B)+TDR	13.00	11.00	28000	20400	1000	3/4	3/8	3/4	3/8	3/4	3/8	0.063	A4TXV01
	E(C,H,M,U)1P29A+TDR	13.00	11.00	28000	20400	1000	3/4	3/8	3/4	3/8	3/4	3/8	0.063	A4TXV01
	E(C,M,U)1P30(A,B)+TDR	13.00	11.00	28000	20400	1000	3/4	3/8	3/4	3/8	3/4	3/8	0.063	A4TXV01
	E(C,H,M,U)1P36(A,B,C)+TDR	13.00	11.00	28000	20400	1000	3/4	3/8	3/4	3/8	3/4	3/8	0.063	A4TXV01
4AC13*36P-7, 8	E(C,H,M,U)1P36(B,C)+TDR	13.00	11.00	34000	25000	1200	3/4	3/8	7/8	3/8	3/4 ⁶	3/8	0.072	A4TXV01
	E(C,H,M,U)1P43(B,C)+TDR	13.00	11.00	34000	25000	1200	3/4	3/8	7/8	3/8	3/4 ⁶	3/8	0.072	A4TXV01
	E(C,H,M,U)1P50C+TDR	13.00	11.00	34000	25000	1200	3/4	3/8	7/8	3/8	3/4 ⁶	3/8	0.072	A4TXV01
4AC13*42P-7, 8	E(C,H,M,U)1P43C+TDR	13.00	11.00	40000	29200	1400	3/4	3/8	7/8	3/8	3/4 ⁶	3/8	0.075	A4TXV01
	E(C,H,U)1P49C+TDR	13.00	11.00	40000	29200	1400	3/4	3/8	7/8	3/8	3/4 ⁶	3/8	0.075	A4TXV01
	E(C,H,M,U)1P50C+TDR	13.00	11.00	40000	29200	1400	3/4	3/8	7/8	3/8	3/4 ⁶	3/8	0.075	A4TXV01
4AC13*48P-7, 8	E(C,H,U)1P49C+TDR	13.00	11.00	47000	34300	1600	7/8	3/8	7/8	3/8	7/8	3/8	0.082	A4TXV02
	E(C,H,U)1P62C+TDR	13.00	11.00	47000	34300	1600	7/8	3/8	7/8	3/8	7/8	3/8	0.082	A4TXV02
	E(C,H,U)1P62D+TDR	13.00	11.00	47000	34300	1600	7/8	3/8	7/8	3/8	7/8	3/8	0.082	A4TXV02
4AC13*60P-7, 8	E(C,H,U)1P49C+TDR	13.00	11.00	57000	41000	1800	7/8	3/8	7/8	3/8	7/8 ⁷	3/8	0.090	A4TXV02
	E(C,H,U)1P62C+TDR	13.00	11.00	57000	41000	1800	7/8	3/8	7/8	3/8	7/8 ⁷	3/8	0.090	A4TXV02
	E(C,H,U)1P62D+TDR	13.00	11.00	57000	41000	1800	7/8	3/8	7/8	3/8	7/8 ⁷	3/8	0.090	A4TXV02

¹ Certified in accordance with Unitary Air Conditioner Certification Program, which is based on AHRI Standard 210/240.

² Required to achieve AHRI rating.

* = B or L B = Wire Guard L = Louvered

Note:

¹ Certified in accordance with Unitary Air Conditioner Certification Program, which is based on AHRI Standard 210/240

² Required to achieve AHRI rating. If NA (Not Applicable) is in the piston column, then TXV is required.

³ A blower time delay relay is required to achieve AHRI rating. This feature is standard on all Allied Air Enterprises furnace and AH products.

⁴ For lines 25 ft or over, use 3/8"

⁵ For lines 25 ft or over, use 3/4"

⁶ For lines 25 ft or over, use 7/8"

⁷ For lines 25 ft or over, use 1-1/8"

Cooling Performance with Air Handlers and Furnaces 18

Outdoor Model	Indoor Model	Variable Speed Furnace	SEER	EER	Rated ARI Capacity ¹ BTUH	Rated Sensible Capacity BTUH	CFM	Refrigerant Connection				Refrigerant Line Size		Indoor Expansion Device		
	Evaporator Coil or Air Handler ³							Outdoor		Indoor		Suction	Liquid	Piston ²	TXV	
								Suction	Liquid	Suction	Liquid					
4AC13*18P-7.8	BCS3M18C****P BCE3M18C****P		13.0	11.0	17,600	13,380	650	3/4	3/8	3/4	3/8	5/8 ⁵	3/8 or 1/4 ⁴	0.053	A4TXV01	
	BCS3M24C****P BCE3M24C****P		13.0	11.0	17,600	13,380	650	3/4	3/8	3/4	3/8	5/8 ⁵	3/8 or 1/4 ⁴	0.053	A4TXV01	
	BCS2M24V****P		14.0	12.0	17,600	13,380	650	3/4	3/8	3/4	3/8	5/8 ⁵	3/8 or 1/4 ⁴	0.053	A4TXV01	
	BCS3M24E****P		14.0	11.0	17,600	13,380	650	3/4	3/8	3/4	3/8	5/8 ⁵	3/8 or 1/4 ⁴	0.053	A4TXV01	
	E(C,H,M,U)1P23A	80G1DF045AE12		14.0	12.0	18,000	13,680	650	3/4	3/8	3/4	3/8	5/8 ⁵	3/8 or 1/4 ⁴	0.053	A4TXV01
	E(C,H,M,U)1P23A	80G1UH045AE12		14.0	12.0	18,000	13,680	650	3/4	3/8	3/4	3/8	5/8 ⁵	3/8 or 1/4 ⁴	0.053	A4TXV01
	E(C,H,M,U)1P23A	80G2UH070AV12		14.0	12.0	17,600	13,380	650	3/4	3/8	3/4	3/8	5/8 ⁵	3/8 or 1/4 ⁴	0.053	A4TXV01
	E(C,H,M,U)1P23B	80G1DF070BE12		14.0	12.0	18,000	13,680	650	3/4	3/8	3/4	3/8	5/8 ⁵	3/8 or 1/4 ⁴	0.053	A4TXV01
	E(C,H,M,U)1P23B	80G1UH070BE12		14.0	12.0	18,000	13,680	650	3/4	3/8	3/4	3/8	5/8 ⁵	3/8 or 1/4 ⁴	0.053	A4TXV01
	E(C,H,M,U)1P23B	95G1DF045BE12		14.0	12.0	18,000	13,680	650	3/4	3/8	3/4	3/8	5/8 ⁵	3/8 or 1/4 ⁴	0.053	A4TXV01
	E(C,H,M,U)1P23B	95G1UH045BE12		14.0	12.0	18,000	13,680	650	3/4	3/8	3/4	3/8	5/8 ⁵	3/8 or 1/4 ⁴	0.053	A4TXV01
	E(C,H,M,U)1P23B	95G1UH070BE12		14.0	11.5	18,000	13,680	650	3/4	3/8	3/4	3/8	5/8 ⁵	3/8 or 1/4 ⁴	0.053	A4TXV01
	E(C,H,M,U)1P23B	95G2DF045BV12		14.0	12.0	18,000	13,680	650	3/4	3/8	3/4	3/8	5/8 ⁵	3/8 or 1/4 ⁴	0.053	A4TXV01
	E(C,H,M,U)1P23B	95G2DF070BV16		14.0	12.0	18,000	13,680	650	3/4	3/8	3/4	3/8	5/8 ⁵	3/8 or 1/4 ⁴	0.053	A4TXV01
	E(C,H,M,U)1P23B	95G2UH045BV12		14.0	12.0	18,000	13,680	650	3/4	3/8	3/4	3/8	5/8 ⁵	3/8 or 1/4 ⁴	0.053	A4TXV01
	E(C,H,M,U)1P23B	95G2UH070BV12		14.0	12.0	18,000	13,680	650	3/4	3/8	3/4	3/8	5/8 ⁵	3/8 or 1/4 ⁴	0.053	A4TXV01
	E(C,H,M,U)1P29A	80G1DF045AE12		14.0	12.0	18,000	13,680	650	3/4	3/8	3/4	3/8	5/8 ⁵	3/8 or 1/4 ⁴	0.053	A4TXV01
	E(C,H,M,U)1P29A	80G1UH045AE12		14.0	12.0	18,000	13,680	650	3/4	3/8	3/4	3/8	5/8 ⁵	3/8 or 1/4 ⁴	0.053	A4TXV01
	E(C,H,M,U)1P29A	80G2UH070AV12		14.0	12.0	17,600	13,380	650	3/4	3/8	3/4	3/8	5/8 ⁵	3/8 or 1/4 ⁴	0.053	A4TXV01
	E(C,H,M,U)1P29B	80G1DF070BE12		14.0	12.0	18,000	13,680	650	3/4	3/8	3/4	3/8	5/8 ⁵	3/8 or 1/4 ⁴	0.053	A4TXV01
	E(C,H,M,U)1P29B	80G1UH070BE12		14.0	12.0	18,000	13,680	650	3/4	3/8	3/4	3/8	5/8 ⁵	3/8 or 1/4 ⁴	0.053	A4TXV01
	E(C,H,M,U)1P29B	95G1DF045BE12		14.0	12.0	18,000	13,680	650	3/4	3/8	3/4	3/8	5/8 ⁵	3/8 or 1/4 ⁴	0.053	A4TXV01
	E(C,H,M,U)1P29B	95G1UH045BE12		14.0	12.0	18,000	13,680	650	3/4	3/8	3/4	3/8	5/8 ⁵	3/8 or 1/4 ⁴	0.053	A4TXV01
	E(C,H,M,U)1P29B	95G1UH070BE12		14.0	12.0	18,000	13,680	650	3/4	3/8	3/4	3/8	5/8 ⁵	3/8 or 1/4 ⁴	0.053	A4TXV01
	E(C,H,M,U)1P29B	95G2DF045BV12		14.0	12.0	18,000	13,680	650	3/4	3/8	3/4	3/8	5/8 ⁵	3/8 or 1/4 ⁴	0.053	A4TXV01
	E(C,H,M,U)1P29B	95G2DF070BV16		14.0	12.0	18,000	13,680	650	3/4	3/8	3/4	3/8	5/8 ⁵	3/8 or 1/4 ⁴	0.053	A4TXV01
	E(C,H,M,U)1P29B	95G2UH045BV12		14.0	12.0	18,000	13,680	650	3/4	3/8	3/4	3/8	5/8 ⁵	3/8 or 1/4 ⁴	0.053	A4TXV01
	E(C,H,M,U)1P29B	95G2UH070BV12		14.0	12.0	18,000	13,680	650	3/4	3/8	3/4	3/8	5/8 ⁵	3/8 or 1/4 ⁴	0.053	A4TXV01
	E(C,M,U)1P19A	80G1DF045AE12		14.0	11.5	18,000	13,680	650	3/4	3/8	3/4	3/8	5/8 ⁵	3/8 or 1/4 ⁴	0.053	A4TXV01
	E(C,M,U)1P19A	80G1UH045AE12		14.0	11.5	18,000	13,680	650	3/4	3/8	3/4	3/8	5/8 ⁵	3/8 or 1/4 ⁴	0.053	A4TXV01
	E(C,M,U)1P19A	80G2UH070AV12		13.5	11.5	17,600	13,380	650	3/4	3/8	3/4	3/8	5/8 ⁵	3/8 or 1/4 ⁴	0.053	A4TXV01

* = B or L B = Wire Guard

L = Louvered

Note:

¹ Certified in accordance with Unitary Air Conditioner Certification Program, which is based on AHRI Standard 210/240

² Required to achieve AHRI rating. If NA (Not Applicable) is in the piston column, then TXV is required.

³ A blower time delay relay is required to achieve AHRI rating. This feature is standard on all Allied Air Enterprises furnace and AH products.

⁴ For lines 25 ft or over, use 3/8"

⁵ For lines 25 ft or over, use 3/4"

Cooling Performance with Air Handlers and Furnaces 18, 24

Outdoor Model	Indoor Model	Variable Speed Furnace	SEER	EER	Rated ARI Capacity ¹ BTUH	Rated Sensible Capacity BTUH	CFM	Refrigerant Connection				Refrigerant Line Size		Indoor Expansion Device	
	Evaporator Coil or Air Handler ³							Outdoor		Indoor		Suction	Liquid	Piston ²	TXV
								Suction	Liquid	Suction	Liquid				
4AC13*18P-7.8	E(C,M,U)1P19B	80G1DF070BE12	14.0	11.5	18,000	13,680	650	3/4	3/8	3/4	3/8	5/8 ⁵	3/8 or 1/4 ⁴	0.053	A4TXV01
	E(C,M,U)1P19B	80G1UH070BE12	14.0	11.5	18,000	13,680	650	3/4	3/8	3/4	3/8	5/8 ⁵	3/8 or 1/4 ⁴	0.053	A4TXV01
	E(C,M,U)1P19B	95G1DF045BE12	14.0	11.5	18,000	13,680	650	3/4	3/8	3/4	3/8	5/8 ⁵	3/8 or 1/4 ⁴	0.053	A4TXV01
	E(C,M,U)1P19B	95G1UH045BE12	14.0	11.5	18,000	13,680	650	3/4	3/8	3/4	3/8	5/8 ⁵	3/8 or 1/4 ⁴	0.053	A4TXV01
	E(C,M,U)1P19B	95G1UH070BE12	14.0	11.5	18,000	13,680	650	3/4	3/8	3/4	3/8	5/8 ⁵	3/8 or 1/4 ⁴	0.053	A4TXV01
	E(C,M,U)1P19B	95G2DF045BV12	14.0	11.5	18,000	13,680	650	3/4	3/8	3/4	3/8	5/8 ⁵	3/8 or 1/4 ⁴	0.053	A4TXV01
	E(C,M,U)1P19B	95G2UH070BV16	14.0	11.5	18,000	13,680	650	3/4	3/8	3/4	3/8	5/8 ⁵	3/8 or 1/4 ⁴	0.053	A4TXV01
	E(C,M,U)1P19B	95G2UH045BV12	14.0	11.5	18,000	13,680	650	3/4	3/8	3/4	3/8	5/8 ⁵	3/8 or 1/4 ⁴	0.053	A4TXV01
	E(C,M,U)1P19B	95G2UH070BV12	14.0	11.5	18,000	13,680	650	3/4	3/8	3/4	3/8	5/8 ⁵	3/8 or 1/4 ⁴	0.053	A4TXV01
	E(C,M,U)1P24A	80G1DF045AE12	14.0	12.0	18,000	13,680	650	3/4	3/8	3/4	3/8	5/8 ⁵	3/8 or 1/4 ⁴	0.053	A4TXV01
	E(C,M,U)1P24A	80G1UH045AE12	14.0	11.5	18,000	13,680	650	3/4	3/8	3/4	3/8	5/8 ⁵	3/8 or 1/4 ⁴	0.053	A4TXV01
	E(C,M,U)1P24A	80G2UH070AV12	13.5	11.5	17,600	13,380	650	3/4	3/8	3/4	3/8	5/8 ⁵	3/8 or 1/4 ⁴	0.053	A4TXV01
	E(C,M,U)1P24B	80G1DF070BE12	14.0	11.5	18,000	13,680	650	3/4	3/8	3/4	3/8	5/8 ⁵	3/8 or 1/4 ⁴	0.053	A4TXV01
	E(C,M,U)1P24B	80G1UH070BE12	14.0	11.5	18,000	13,680	650	3/4	3/8	3/4	3/8	5/8 ⁵	3/8 or 1/4 ⁴	0.053	A4TXV01
	E(C,M,U)1P24B	95G1DF045BE12	14.0	11.5	18,000	13,680	650	3/4	3/8	3/4	3/8	5/8 ⁵	3/8 or 1/4 ⁴	0.053	A4TXV01
	E(C,M,U)1P24B	95G1UH045BE12	14.0	11.5	18,000	13,680	650	3/4	3/8	3/4	3/8	5/8 ⁵	3/8 or 1/4 ⁴	0.053	A4TXV01
	E(C,M,U)1P24B	95G1UH070BE12	14.0	11.5	18,000	13,680	650	3/4	3/8	3/4	3/8	5/8 ⁵	3/8 or 1/4 ⁴	0.053	A4TXV01
	E(C,M,U)1P24B	95G2DF045BV12	14.0	12.0	18,000	13,680	650	3/4	3/8	3/4	3/8	5/8 ⁵	3/8 or 1/4 ⁴	0.053	A4TXV01
	E(C,M,U)1P24B	95G2UH070BV16	14.0	12.0	18,000	13,680	650	3/4	3/8	3/4	3/8	5/8 ⁵	3/8 or 1/4 ⁴	0.053	A4TXV01
	E(C,M,U)1P24B	95G2UH045BV12	14.0	12.0	18,000	13,680	650	3/4	3/8	3/4	3/8	5/8 ⁵	3/8 or 1/4 ⁴	0.053	A4TXV01
4AC13*24P-7.8	BCS3M24C****P BCE3M24C****P		13.0	11.0	22,800	17,330	800	3/4	3/8	3/4	3/8	5/8 ⁵	3/8 or 1/4 ⁴	0.057	A4TXV01
	BCS2M24V****P		14.0	12.0	22,800	17,330	800	3/4	3/8	3/4	3/8	5/8 ⁵	3/8 or 1/4 ⁴	0.057	A4TXV01
	BCS3M30E****P		14.0	11.0	22,800	17,330	800	3/4	3/8	3/4	3/8	5/8 ⁵	3/8 or 1/4 ⁴	0.057	A4TXV01
	E(C,H,M,U)1P23A	80G1DF045AE12	14.0	12.0	23,000	17,480	800	3/4	3/8	3/4	3/8	5/8 ⁵	3/8 or 1/4 ⁴	0.057	A4TXV01
	E(C,H,M,U)1P23A	80G1UH045AE12	14.0	12.0	23,000	17,480	800	3/4	3/8	3/4	3/8	5/8 ⁵	3/8 or 1/4 ⁴	0.057	A4TXV01
	E(C,H,M,U)1P23A	80G2UH070AV12	14.0	12.0	22,800	17,330	800	3/4	3/8	3/4	3/8	5/8 ⁵	3/8 or 1/4 ⁴	0.057	A4TXV01
	E(C,H,M,U)1P23B	80G1DF070BE12	13.5	11.5	23,000	17,480	800	3/4	3/8	3/4	3/8	5/8 ⁵	3/8 or 1/4 ⁴	0.057	A4TXV01
	E(C,H,M,U)1P23B	80G1UH070BE12	13.5	11.5	23,000	17,480	800	3/4	3/8	3/4	3/8	5/8 ⁵	3/8 or 1/4 ⁴	0.057	A4TXV01
	E(C,H,M,U)1P23B	95G1DF045BE12	14.0	12.0	22,800	17,330	800	3/4	3/8	3/4	3/8	5/8 ⁵	3/8 or 1/4 ⁴	0.057	A4TXV01
	E(C,H,M,U)1P23B	95G1UH045BE12	14.0	12.0	22,800	17,330	800	3/4	3/8	3/4	3/8	5/8 ⁵	3/8 or 1/4 ⁴	0.057	A4TXV01

* = B or L B = Wire Guard

L = Louvered

Note:

¹ Certified in accordance with Unitary Air Conditioner Certification Program, which is based on AHRI Standard 210/240

² Required to achieve AHRI rating. If NA (Not Applicable) is in the piston column, then TXV is required.

³ A blower time delay relay is required to achieve AHRI rating. This feature is standard on all Allied Air Enterprises furnace and AH products.

⁴ For lines 25 ft or over, use 3/8"

⁵ For lines 25 ft or over, use 3/4"

Cooling Performance with Air Handlers and Furnaces 24

Outdoor Model	Indoor Model	Variable Speed Furnace	SEER	EER	Rated ARI Capacity ¹ BTUH	Rated Sensible Capacity BTUH	CFM	Refrigerant Connection				Refrigerant Line Size		Indoor Expansion Device	
	Evaporator Coil or Air Handler ³							Outdoor		Indoor		Suction	Liquid	Piston ²	TXV
								Suction	Liquid	Suction	Liquid				
4AC13*24P-7,8	E(C,H,M,U)1P23B	95G1UH070BE12	14.0	12.0	23,000	17,480	800	3/4	3/8	3/4	3/8	5/8 ⁵	3/8 or 1/4 ⁴	0.057	A4TXV01
	E(C,H,M,U)1P23B	95G2DF045BV12	14.0	12.0	23,000	17,480	800	3/4	3/8	3/4	3/8	5/8 ⁵	3/8 or 1/4 ⁴	0.057	A4TXV01
	E(C,H,M,U)1P23B	95G2DF070BV16	14.0	12.0	23,000	17,480	800	3/4	3/8	3/4	3/8	5/8 ⁵	3/8 or 1/4 ⁴	0.057	A4TXV01
	E(C,H,M,U)1P23B	95G2UH045BV12	14.0	12.0	23,000	17,480	800	3/4	3/8	3/4	3/8	5/8 ⁵	3/8 or 1/4 ⁴	0.057	A4TXV01
	E(C,H,M,U)1P23B	95G2UH070BV12	14.0	12.0	23,000	17,480	800	3/4	3/8	3/4	3/8	5/8 ⁵	3/8 or 1/4 ⁴	0.057	A4TXV01
	E(C,H,M,U)1P29A	80G1DF045AE12	14.0	12.0	23,000	17,480	800	3/4	3/8	3/4	3/8	5/8 ⁵	3/8 or 1/4 ⁴	0.057	A4TXV01
	E(C,H,M,U)1P29A	80G1UH045AE12	14.0	12.0	23,000	17,480	800	3/4	3/8	3/4	3/8	5/8 ⁵	3/8 or 1/4 ⁴	0.057	A4TXV01
	E(C,H,M,U)1P29A	80G2UH070AV12	14.0	12.0	22,800	17,330	800	3/4	3/8	3/4	3/8	5/8 ⁵	3/8 or 1/4 ⁴	0.057	A4TXV01
	E(C,H,M,U)1P29B	80G1DF070BE12	14.0	12.0	23,000	17,480	800	3/4	3/8	3/4	3/8	5/8 ⁵	3/8 or 1/4 ⁴	0.057	A4TXV01
	E(C,H,M,U)1P29B	80G1UH070BE12	14.0	12.0	23,000	17,480	800	3/4	3/8	3/4	3/8	5/8 ⁵	3/8 or 1/4 ⁴	0.057	A4TXV01
	E(C,H,M,U)1P29B	95G1DF045BE12	14.0	12.0	22,800	17,330	800	3/4	3/8	3/4	3/8	5/8 ⁵	3/8 or 1/4 ⁴	0.057	A4TXV01
	E(C,H,M,U)1P29B	95G1UH045BE12	14.0	12.0	22,800	17,330	800	3/4	3/8	3/4	3/8	5/8 ⁵	3/8 or 1/4 ⁴	0.057	A4TXV01
	E(C,H,M,U)1P29B	95G1UH070BE12	14.0	12.0	23,000	17,480	800	3/4	3/8	3/4	3/8	5/8 ⁵	3/8 or 1/4 ⁴	0.057	A4TXV01
	E(C,H,M,U)1P29B	95G2DF045BV12	14.0	12.0	23,000	17,480	800	3/4	3/8	3/4	3/8	5/8 ⁵	3/8 or 1/4 ⁴	0.057	A4TXV01
	E(C,H,M,U)1P29B	95G2DF070BV16	14.0	12.0	23,000	17,480	800	3/4	3/8	3/4	3/8	5/8 ⁵	3/8 or 1/4 ⁴	0.057	A4TXV01
	E(C,H,M,U)1P29B	95G2UH045BV12	14.0	12.0	23,000	17,480	800	3/4	3/8	3/4	3/8	5/8 ⁵	3/8 or 1/4 ⁴	0.057	A4TXV01
	E(C,H,M,U)1P29B	95G2UH070BV12	14.0	12.0	23,000	17,480	800	3/4	3/8	3/4	3/8	5/8 ⁵	3/8 or 1/4 ⁴	0.057	A4TXV01
	E(C,H,M,U)1P36A	80G1DF045AE12	14.0	12.0	23,000	17,480	800	3/4	3/8	3/4	3/8	5/8 ⁵	3/8 or 1/4 ⁴	0.057	A4TXV01
	E(C,H,M,U)1P36A	80G1UH045AE12	14.0	12.0	23,000	17,480	800	3/4	3/8	3/4	3/8	5/8 ⁵	3/8 or 1/4 ⁴	0.057	A4TXV01
	E(C,H,M,U)1P36A	80G2UH070AV12	14.0	12.0	22,800	17,330	800	3/4	3/8	3/4	3/8	5/8 ⁵	3/8 or 1/4 ⁴	0.057	A4TXV01
	E(C,H,M,U)1P36B	80G1DF070BE12	14.0	12.0	23,000	17,480	800	3/4	3/8	3/4	3/8	5/8 ⁵	3/8 or 1/4 ⁴	0.057	A4TXV01
	E(C,H,M,U)1P36B	80G1UH070BE12	14.0	12.0	23,000	17,480	800	3/4	3/8	3/4	3/8	5/8 ⁵	3/8 or 1/4 ⁴	0.057	A4TXV01
	E(C,H,M,U)1P36B	95G1DF045BE12	14.0	12.0	22,800	17,330	800	3/4	3/8	3/4	3/8	5/8 ⁵	3/8 or 1/4 ⁴	0.057	A4TXV01
	E(C,H,M,U)1P36B	95G1UH045BE12	14.0	12.0	22,800	17,330	800	3/4	3/8	3/4	3/8	5/8 ⁵	3/8 or 1/4 ⁴	0.057	A4TXV01
	E(C,H,M,U)1P36B	95G1UH070BE12	14.0	12.0	23,000	17,480	800	3/4	3/8	3/4	3/8	5/8 ⁵	3/8 or 1/4 ⁴	0.057	A4TXV01
	E(C,H,M,U)1P36B	95G2DF045BV12	14.0	12.0	23,000	17,480	800	3/4	3/8	3/4	3/8	5/8 ⁵	3/8 or 1/4 ⁴	0.057	A4TXV01
	E(C,H,M,U)1P36B	95G2DF070BV16	14.0	12.0	23,000	17,480	800	3/4	3/8	3/4	3/8	5/8 ⁵	3/8 or 1/4 ⁴	0.057	A4TXV01
	E(C,H,M,U)1P36B	95G2UH045BV12	14.0	12.0	23,000	17,480	800	3/4	3/8	3/4	3/8	5/8 ⁵	3/8 or 1/4 ⁴	0.057	A4TXV01
	E(C,H,M,U)1P36B	95G2UH070BV12	14.0	12.0	23,000	17,480	800	3/4	3/8	3/4	3/8	5/8 ⁵	3/8 or 1/4 ⁴	0.057	A4TXV01
	E(C,H,M,U)1P36C	95G2DF090CV20	14.0	12.0	23,000	17,480	800	3/4	3/8	3/4	3/8	5/8 ⁵	3/8 or 1/4 ⁴	0.057	A4TXV01

* = B or L B = Wire Guard L = Louvered

Note:

¹ Certified in accordance with Unitary Air Conditioner Certification Program, which is based on AHRI Standard 210/240

² Required to achieve AHRI rating. If NA (Not Applicable) is in the piston column, then TXV is required.

³ A blower time delay relay is required to achieve AHRI rating. This feature is standard on all Allied Air Enterprises furnace and AH products.

⁴ For lines 25 ft or over, use 3/8"

⁵ For lines 25 ft or over, use 3/4"

Cooling Performance with Air Handlers and Furnaces 24

Outdoor Model	Indoor Model	Variable Speed Furnace	SEER	EER	Rated ARI Capacity ¹ BTUH	Rated Sensible Capacity BTUH	CFM	Refrigerant Connection				Refrigerant Line Size		Indoor Expansion Device	
	Evaporator Coil or Air Handler ³							Outdoor		Indoor		Suction	Liquid	Piston ²	TXV
								Suction	Liquid	Suction	Liquid				
4AC13*24P-7.8	E(C,H,M,U)1P36C	95G2DF110CV20	14.0	12.0	23,000	17,480	800	3/4	3/8	3/4	3/8	5/8 ⁵	3/8 or 1/4 ⁴	0.057	A4TXV01
	E(C,H,M,U)1P36C	95G2UH090CV12	14.0	12.0	23,000	17,480	800	3/4	3/8	3/4	3/8	5/8 ⁵	3/8 or 1/4 ⁴	0.057	A4TXV01
	E(C,M,U)1P19A	80G1DF045AE12	13.5	11.5	23,000	17,480	800	3/4	3/8	3/4	3/8	5/8 ⁵	3/8 or 1/4 ⁴	0.057	A4TXV01
	E(C,M,U)1P19A	80G1UH045AE12	13.5	11.5	23,000	17,480	800	3/4	3/8	3/4	3/8	5/8 ⁵	3/8 or 1/4 ⁴	0.057	A4TXV01
	E(C,M,U)1P19A	80G2UH070AV12	14.0	11.5	22,600	17,180	800	3/4	3/8	3/4	3/8	5/8 ⁵	3/8 or 1/4 ⁴	0.057	A4TXV01
	E(C,M,U)1P19B	80G1DF070BE12	13.5	11.5	23,000	17,480	800	3/4	3/8	3/4	3/8	5/8 ⁵	3/8 or 1/4 ⁴	0.057	A4TXV01
	E(C,M,U)1P19B	80G1UH070BE12	13.5	11.5	23,000	17,480	800	3/4	3/8	3/4	3/8	5/8 ⁵	3/8 or 1/4 ⁴	0.057	A4TXV01
	E(C,M,U)1P19B	95G1DF045BE12	14.0	12.0	22,800	17,330	800	3/4	3/8	3/4	3/8	5/8 ⁵	3/8 or 1/4 ⁴	0.057	A4TXV01
	E(C,M,U)1P19B	95G1UH045BE12	14.0	12.0	22,800	17,330	800	3/4	3/8	3/4	3/8	5/8 ⁵	3/8 or 1/4 ⁴	0.057	A4TXV01
	E(C,M,U)1P19B	95G1UH070BE12	14.0	12.0	23,000	17,480	800	3/4	3/8	3/4	3/8	5/8 ⁵	3/8 or 1/4 ⁴	0.057	A4TXV01
	E(C,M,U)1P19B	95G2DF045BV12	14.0	12.0	23,000	17,480	800	3/4	3/8	3/4	3/8	5/8 ⁵	3/8 or 1/4 ⁴	0.057	A4TXV01
	E(C,M,U)1P19B	95G2DF070BV16	13.5	11.5	23,000	17,480	800	3/4	3/8	3/4	3/8	5/8 ⁵	3/8 or 1/4 ⁴	0.057	A4TXV01
	E(C,M,U)1P19B	95G2UH045BV12	14.0	12.0	23,000	17,480	800	3/4	3/8	3/4	3/8	5/8 ⁵	3/8 or 1/4 ⁴	0.057	A4TXV01
	E(C,M,U)1P19B	95G2UH070BV12	14.0	12.0	23,000	17,480	800	3/4	3/8	3/4	3/8	5/8 ⁵	3/8 or 1/4 ⁴	0.057	A4TXV01
	E(C,M,U)1P24A	80G1DF045AE12	14.0	12.0	23,000	17,480	800	3/4	3/8	3/4	3/8	5/8 ⁵	3/8 or 1/4 ⁴	0.057	A4TXV01
	E(C,M,U)1P24A	80G1UH045AE12	14.0	12.0	23,000	17,480	800	3/4	3/8	3/4	3/8	5/8 ⁵	3/8 or 1/4 ⁴	0.057	A4TXV01
	E(C,M,U)1P24A	80G2UH070AV12	14.0	12.0	22,800	17,330	800	3/4	3/8	3/4	3/8	5/8 ⁵	3/8 or 1/4 ⁴	0.057	A4TXV01
	E(C,M,U)1P24B	80G1DF070BE12	13.5	11.5	23,000	17,480	800	3/4	3/8	3/4	3/8	5/8 ⁵	3/8 or 1/4 ⁴	0.057	A4TXV01
	E(C,M,U)1P24B	80G1UH070BE12	13.5	11.5	23,000	17,480	800	3/4	3/8	3/4	3/8	5/8 ⁵	3/8 or 1/4 ⁴	0.057	A4TXV01
	E(C,M,U)1P24B	95G1DF045BE12	14.0	12.0	22,800	17,330	800	3/4	3/8	3/4	3/8	5/8 ⁵	3/8 or 1/4 ⁴	0.057	A4TXV01
	E(C,M,U)1P24B	95G1UH045BE12	14.0	12.0	22,800	17,330	800	3/4	3/8	3/4	3/8	5/8 ⁵	3/8 or 1/4 ⁴	0.057	A4TXV01
	E(C,M,U)1P24B	95G1UH070BE12	14.0	12.0	23,000	17,480	800	3/4	3/8	3/4	3/8	5/8 ⁵	3/8 or 1/4 ⁴	0.057	A4TXV01
	E(C,M,U)1P24B	95G2DF045BV12	14.0	12.0	23,000	17,480	800	3/4	3/8	3/4	3/8	5/8 ⁵	3/8 or 1/4 ⁴	0.057	A4TXV01
	E(C,M,U)1P24B	95G2DF070BV16	14.0	12.0	23,000	17,480	800	3/4	3/8	3/4	3/8	5/8 ⁵	3/8 or 1/4 ⁴	0.057	A4TXV01
	E(C,M,U)1P24B	95G2UH045BV12	14.0	12.0	23,000	17,480	800	3/4	3/8	3/4	3/8	5/8 ⁵	3/8 or 1/4 ⁴	0.057	A4TXV01
	E(C,M,U)1P24B	95G2UH070BV12	14.0	12.0	23,000	17,480	800	3/4	3/8	3/4	3/8	5/8 ⁵	3/8 or 1/4 ⁴	0.057	A4TXV01
	E(C,M,U)1P30A	80G1DF045AE12	14.0	12.0	23,000	17,480	800	3/4	3/8	3/4	3/8	5/8 ⁵	3/8 or 1/4 ⁴	0.057	A4TXV01
	E(C,M,U)1P30A	80G1UH045AE12	14.0	12.0	23,000	17,480	800	3/4	3/8	3/4	3/8	5/8 ⁵	3/8 or 1/4 ⁴	0.057	A4TXV01
	E(C,M,U)1P30A	80G2UH070AV12	14.0	12.0	22,800	17,330	800	3/4	3/8	3/4	3/8	5/8 ⁵	3/8 or 1/4 ⁴	0.057	A4TXV01
	E(C,M,U)1P30B	80G1DF070BE12	14.0	12.0	23,000	17,480	800	3/4	3/8	3/4	3/8	5/8 ⁵	3/8 or 1/4 ⁴	0.057	A4TXV01

* = B or L B = Wire Guard

L = Louvered

Note:

¹ Certified in accordance with Unitary Air Conditioner Certification Program, which is based on AHRI Standard 210/240

² Required to achieve AHRI rating. If NA (Not Applicable) is in the piston column, then TXV is required.

³ A blower time delay relay is required to achieve AHRI rating. This feature is standard on all Allied Air Enterprises furnace and AH products.

⁴ For lines 25 ft or over, use 3/8"

⁵ For lines 25 ft or over, use 3/4"

Cooling Performance with Air Handlers and Furnaces 24, 30

Outdoor Model	Indoor Model	Variable Speed Furnace	SEER	EER	Rated ARI Capacity ¹ BTUH	Rated Sensible Capacity BTUH	CFM	Refrigerant Connection				Refrigerant Line Size		Indoor Expansion Device	
	Evaporator Coil or Air Handler ³							Outdoor		Indoor		Suction	Liquid	Piston ²	TXV
								Suction	Liquid	Suction	Liquid				
4AC13*24P-7,8	E(C,M,U)1P30B	80G1UH070BE12	14.0	12.0	23,000	17,480	800	3/4	3/8	3/4	3/8	5/8 ⁵	3/8 or 1/4 ⁴	0.057	A4TXV01
	E(C,M,U)1P30B	95G1DF045BE12	14.0	12.0	22,800	17,330	800	3/4	3/8	3/4	3/8	5/8 ⁵	3/8 or 1/4 ⁴	0.057	A4TXV01
	E(C,M,U)1P30B	95G1UH045BE12	14.0	12.0	22,800	17,330	800	3/4	3/8	3/4	3/8	5/8 ⁵	3/8 or 1/4 ⁴	0.057	A4TXV01
	E(C,M,U)1P30B	95G1UH070BE12	14.0	12.0	23,000	17,480	800	3/4	3/8	3/4	3/8	5/8 ⁵	3/8 or 1/4 ⁴	0.057	A4TXV01
	E(C,M,U)1P30B	95G2DF045BV12	14.0	12.0	23,000	17,480	800	3/4	3/8	3/4	3/8	5/8 ⁵	3/8 or 1/4 ⁴	0.057	A4TXV01
	E(C,M,U)1P30B	95G2DF070BV16	14.0	12.0	23,000	17,480	800	3/4	3/8	3/4	3/8	5/8 ⁵	3/8 or 1/4 ⁴	0.057	A4TXV01
	E(C,M,U)1P30B	95G2UH045BV12	14.0	12.0	23,000	17,480	800	3/4	3/8	3/4	3/8	5/8 ⁵	3/8 or 1/4 ⁴	0.057	A4TXV01
	E(C,M,U)1P30B	95G2UH070BV12	14.0	12.0	23,000	17,480	800	3/4	3/8	3/4	3/8	5/8 ⁵	3/8 or 1/4 ⁴	0.057	A4TXV01
4AC13*30P-7,8	BCS3M30C****P BCE3M30C****P		13.0	11.0	28,000	21,000	1000	3/4	3/8	3/4	3/8	3/4	3/8	0.063	A4TXV01
	BCS2M36V****P		14.0	12.0	28,000	21,000	1000	3/4	3/8	3/4	3/8	3/4	3/8	0.063	A4TXV01
	BCS3M30E****P		14.0	11.0	28,000	21,000	1000	3/4	3/8	3/4	3/8	3/4	3/8	0.063	A4TXV01
	E(C,H,M,U)1P23A	80G1DF045AE12	13.5	11.5	29,000	21,750	1000	3/4	3/8	3/4	3/8	3/4	3/8	0.063	A4TXV01
	E(C,H,M,U)1P23A	80G1UH045AE12	14.0	12.0	29,000	21,750	1000	3/4	3/8	3/4	3/8	3/4	3/8	0.063	A4TXV01
	E(C,H,M,U)1P23A	80G2UH070AV12	13.5	11.5	28,000	21,000	1000	3/4	3/8	3/4	3/8	3/4	3/8	0.063	A4TXV01
	E(C,H,M,U)1P23B	80G1DF070BE12	14.0	12.0	29,000	21,750	1000	3/4	3/8	3/4	3/8	3/4	3/8	0.063	A4TXV01
	E(C,H,M,U)1P23B	80G1DF090BE16	14.0	12.0	29,000	21,750	1000	3/4	3/8	3/4	3/8	3/4	3/8	0.063	A4TXV01
	E(C,H,M,U)1P23B	80G1UH070BE12	14.0	12.0	29,000	21,750	1000	3/4	3/8	3/4	3/8	3/4	3/8	0.063	A4TXV01
	E(C,H,M,U)1P23B	80G1UH090BE16	14.0	12.0	29,000	21,750	1000	3/4	3/8	3/4	3/8	3/4	3/8	0.063	A4TXV01
	E(C,H,M,U)1P23B	95G1DF045BE12	13.5	11.5	29,000	21,750	1000	3/4	3/8	3/4	3/8	3/4	3/8	0.063	A4TXV01
	E(C,H,M,U)1P23B	95G1DF070BE16	13.5	11.5	29,000	21,750	1000	3/4	3/8	3/4	3/8	3/4	3/8	0.063	A4TXV01
	E(C,H,M,U)1P23B	95G1UH045BE12	13.5	11.5	29,000	21,750	1000	3/4	3/8	3/4	3/8	3/4	3/8	0.063	A4TXV01
	E(C,H,M,U)1P23B	95G1UH070BE12	13.5	11.5	29,000	21,750	1000	3/4	3/8	3/4	3/8	3/4	3/8	0.063	A4TXV01
	E(C,H,M,U)1P23B	95G2DF045BV12	14.0	12.0	29,000	21,750	1000	3/4	3/8	3/4	3/8	3/4	3/8	0.063	A4TXV01
	E(C,H,M,U)1P23B	95G2DF070BV16	13.5	11.5	29,000	21,750	1000	3/4	3/8	3/4	3/8	3/4	3/8	0.063	A4TXV01
	E(C,H,M,U)1P23B	95G2UH045BV12	13.5	11.5	29,000	21,750	1000	3/4	3/8	3/4	3/8	3/4	3/8	0.063	A4TXV01
	E(C,H,M,U)1P23B	95G2UH070BV12	14.0	12.0	29,000	21,750	1000	3/4	3/8	3/4	3/8	3/4	3/8	0.063	A4TXV01
	E(C,H,M,U)1P29A	80G1DF045AE12	13.5	11.5	29,000	21,750	1000	3/4	3/8	3/4	3/8	3/4	3/8	0.063	A4TXV01
	E(C,H,M,U)1P29A	80G1UH045AE12	14.0	12.0	29,000	21,750	1000	3/4	3/8	3/4	3/8	3/4	3/8	0.063	A4TXV01
E(C,H,M,U)1P29A	80G2UH070AV12	13.5	11.5	28,000	21,750	1000	3/4	3/8	3/4	3/8	3/4	3/8	0.063	A4TXV01	
E(C,H,M,U)1P29B	80G1DF070BE12	14.0	12.0	29,000	21,750	1000	3/4	3/8	3/4	3/8	3/4	3/8	0.063	A4TXV01	

* = B or L B = Wire Guard

L = Louvered

Note:

¹ Certified in accordance with Unitary Air Conditioner Certification Program, which is based on AHRI Standard 210/240

² Required to achieve AHRI rating. If NA (Not Applicable) is in the piston column, then TXV is required.

³ A blower time delay relay is required to achieve AHRI rating. This feature is standard on all Allied Air Enterprises furnace and AH products.

⁴ For lines 25 ft or over, use 3/8"

⁵ For lines 25 ft or over, use 3/4"

Cooling Performance with Air Handlers and Furnaces 30

Outdoor Model	Indoor Model	Variable Speed Furnace	SEER	EER	Rated ARI Capacity ¹ BTUH	Rated Sensible Capacity BTUH	CFM	Refrigerant Connection				Refrigerant Line Size		Indoor Expansion Device	
	Evaporator Coil or Air Handler ³							Outdoor		Indoor		Suction	Liquid	Piston ²	TXV
								Suction	Liquid	Suction	Liquid				
4AC13*30P-7,8	E(C,H,M,U)1P29B	80G1DF090BE16	14.0	12.0	29,000	21,750	1000	3/4	3/8	3/4	3/8	3/4	3/8	0.063	A4TXV01
	E(C,H,M,U)1P29B	80G1UH070BE12	14.0	12.0	29,000	21,750	1000	3/4	3/8	3/4	3/8	3/4	3/8	0.063	A4TXV01
	E(C,H,M,U)1P29B	80G1UH090BE16	14.0	12.0	29,000	21,750	1000	3/4	3/8	3/4	3/8	3/4	3/8	0.063	A4TXV01
	E(C,H,M,U)1P29B	95G1DF045BE12	13.5	12.0	29,000	21,750	1000	3/4	3/8	3/4	3/8	3/4	3/8	0.063	A4TXV01
	E(C,H,M,U)1P29B	95G1DF070BE16	13.5	11.5	29,000	21,750	1000	3/4	3/8	3/4	3/8	3/4	3/8	0.063	A4TXV01
	E(C,H,M,U)1P29B	95G1UH045BE12	13.5	12.0	29,000	21,750	1000	3/4	3/8	3/4	3/8	3/4	3/8	0.063	A4TXV01
	E(C,H,M,U)1P29B	95G1UH070BE12	13.5	12.0	29,000	21,750	1000	3/4	3/8	3/4	3/8	3/4	3/8	0.063	A4TXV01
	E(C,H,M,U)1P29B	95G2DF045BV12	14.0	12.0	29,000	21,750	1000	3/4	3/8	3/4	3/8	3/4	3/8	0.063	A4TXV01
	E(C,H,M,U)1P29B	95G2DF070BV16	14.0	12.0	29,000	21,750	1000	3/4	3/8	3/4	3/8	3/4	3/8	0.063	A4TXV01
	E(C,H,M,U)1P29B	95G2UH045BV12	13.5	11.5	29,000	21,750	1000	3/4	3/8	3/4	3/8	3/4	3/8	0.063	A4TXV01
	E(C,H,M,U)1P29B	95G2UH070BV12	14.0	12.0	29,000	21,750	1000	3/4	3/8	3/4	3/8	3/4	3/8	0.063	A4TXV01
	E(C,H,M,U)1P36A	80G1DF045AE12	13.5	11.5	29,000	21,750	1000	3/4	3/8	3/4	3/8	3/4	3/8	0.063	A4TXV01
	E(C,H,M,U)1P36A	80G1UH045AE12	13.5	11.5	29,000	21,750	1000	3/4	3/8	3/4	3/8	3/4	3/8	0.063	A4TXV01
	E(C,H,M,U)1P36A	80G2UH070AV12	13.5	11.5	28,000	21,000	1000	3/4	3/8	3/4	3/8	3/4	3/8	0.063	A4TXV01
	E(C,H,M,U)1P36B	80G1DF070BE12	14.0	11.5	29,000	21,750	1000	3/4	3/8	3/4	3/8	3/4	3/8	0.063	A4TXV01
	E(C,H,M,U)1P36B	80G1DF090BE16	14.0	11.5	29,000	21,750	1000	3/4	3/8	3/4	3/8	3/4	3/8	0.063	A4TXV01
	E(C,H,M,U)1P36B	80G1UH070BE12	14.0	11.5	29,000	21,750	1000	3/4	3/8	3/4	3/8	3/4	3/8	0.063	A4TXV01
	E(C,H,M,U)1P36B	80G1UH090BE16	14.0	11.5	29,000	21,750	1000	3/4	3/8	3/4	3/8	3/4	3/8	0.063	A4TXV01
	E(C,H,M,U)1P36B	95G1DF045BE12	13.5	11.5	29,000	21,750	1000	3/4	3/8	3/4	3/8	3/4	3/8	0.063	A4TXV01
	E(C,H,M,U)1P36B	95G1DF070BE16	13.5	11.5	29,000	21,750	1000	3/4	3/8	3/4	3/8	3/4	3/8	0.063	A4TXV01
	E(C,H,M,U)1P36B	95G1UH045BE12	13.5	11.5	29,000	21,750	1000	3/4	3/8	3/4	3/8	3/4	3/8	0.063	A4TXV01
	E(C,H,M,U)1P36B	95G1UH070BE12	13.5	11.5	29,000	21,750	1000	3/4	3/8	3/4	3/8	3/4	3/8	0.063	A4TXV01
	E(C,H,M,U)1P36B	95G2DF045BV12	14.0	11.5	29,000	21,750	1000	3/4	3/8	3/4	3/8	3/4	3/8	0.063	A4TXV01
	E(C,H,M,U)1P36B	95G2DF070BV16	13.5	11.5	29,000	21,750	1000	3/4	3/8	3/4	3/8	3/4	3/8	0.063	A4TXV01
	E(C,H,M,U)1P36B	95G2UH045BV12	13.5	11.5	29,000	21,750	1000	3/4	3/8	3/4	3/8	3/4	3/8	0.063	A4TXV01
	E(C,H,M,U)1P36B	95G2UH070BV12	14.0	11.5	29,000	21,750	1000	3/4	3/8	3/4	3/8	3/4	3/8	0.063	A4TXV01
	E(C,H,M,U)1P36C	95G1DF090CE16	13.5	11.5	29,000	21,750	1000	3/4	3/8	3/4	3/8	3/4	3/8	0.063	A4TXV01
	E(C,H,M,U)1P36C	95G1UH090CE16	13.5	11.5	29,000	21,750	1000	3/4	3/8	3/4	3/8	3/4	3/8	0.063	A4TXV01
	E(C,H,M,U)1P36C	95G2DF090CV20	14.0	12.0	29,000	21,750	1000	3/4	3/8	3/4	3/8	3/4	3/8	0.063	A4TXV01
	E(C,H,M,U)1P36C	95G2DF110CV20	14.0	11.5	29,000	21,750	1000	3/4	3/8	3/4	3/8	3/4	3/8	0.063	A4TXV01

* = B or L B = Wire Guard

L = Louvered

Note:

¹ Certified in accordance with Unitary Air Conditioner Certification Program, which is based on AHRI Standard 210/240

² Required to achieve AHRI rating. If NA (Not Applicable) is in the piston column, then TXV is required.

³ A blower time delay relay is required to achieve AHRI rating. This feature is standard on all Allied Air Enterprises furnace and AH products.

⁴ For lines 25 ft or over, use 3/8"

⁵ For lines 25 ft or over, use 3/4"

Cooling Performance with Air Handlers and Furnaces 30

Outdoor Model	Indoor Model	Variable Speed Furnace	SEER	EER	Rated ARI Capacity ¹ BTUH	Rated Sensible Capacity BTUH	CFM	Refrigerant Connection				Refrigerant Line Size		Indoor Expansion Device	
	Evaporator Coil or Air Handler ³							Outdoor		Indoor		Suction	Liquid	Piston ²	TXV
								Suction	Liquid	Suction	Liquid				
4AC13*30P-7.8	E(C,H,M,U)1P36C	95G2UH090CV12	14.0	11.5	29,000	21,750	1000	3/4	3/8	3/4	3/8	3/4	3/8	0.063	A4TXV01
	E(C,H,M,U)1P43B	80G1DF070BE12	14.0	12.0	29,000	21,750	1000	3/4	3/8	3/4	3/8	3/4	3/8	0.063	A4TXV01
	E(C,H,M,U)1P43B	80G1DF090BE16	14.0	12.0	29,000	21,750	1000	3/4	3/8	3/4	3/8	3/4	3/8	0.063	A4TXV01
	E(C,H,M,U)1P43B	80G1UH070BE12	14.0	12.0	29,000	21,750	1000	3/4	3/8	3/4	3/8	3/4	3/8	0.063	A4TXV01
	E(C,H,M,U)1P43B	80G1UH090BE16	14.0	12.0	29,000	21,750	1000	3/4	3/8	3/4	3/8	3/4	3/8	0.063	A4TXV01
	E(C,H,M,U)1P43B	95G1DF045BE12	13.5	12.0	29,000	21,750	1000	3/4	3/8	3/4	3/8	3/4	3/8	0.063	A4TXV01
	E(C,H,M,U)1P43B	95G1DF070BE16	13.5	12.0	29,000	21,750	1000	3/4	3/8	3/4	3/8	3/4	3/8	0.063	A4TXV01
	E(C,H,M,U)1P43B	95G1UH045BE12	13.5	12.0	29,000	21,750	1000	3/4	3/8	3/4	3/8	3/4	3/8	0.063	A4TXV01
	E(C,H,M,U)1P43B	95G1UH070BE12	13.5	12.0	29,000	21,750	1000	3/4	3/8	3/4	3/8	3/4	3/8	0.063	A4TXV01
	E(C,H,M,U)1P43B	95G2DF045BV12	13.5	12.0	29,000	21,750	1000	3/4	3/8	3/4	3/8	3/4	3/8	0.063	A4TXV01
	E(C,H,M,U)1P43B	95G2DF070BV16	13.5	12.0	29,000	21,750	1000	3/4	3/8	3/4	3/8	3/4	3/8	0.063	A4TXV01
	E(C,H,M,U)1P43B	95G2UH045BV12	13.5	12.0	29,000	21,750	1000	3/4	3/8	3/4	3/8	3/4	3/8	0.063	A4TXV01
	E(C,H,M,U)1P43B	95G2UH070BV12	14.0	12.0	29,000	21,750	1000	3/4	3/8	3/4	3/8	3/4	3/8	0.063	A4TXV01
	E(C,H,M,U)1P43C	95G1DF090CE16	13.5	12.0	29,000	21,750	1000	3/4	3/8	3/4	3/8	3/4	3/8	0.063	A4TXV01
	E(C,H,M,U)1P43C	95G1UH090CE16	13.5	12.0	29,000	21,750	1000	3/4	3/8	3/4	3/8	3/4	3/8	0.063	A4TXV01
	E(C,H,M,U)1P43C	95G2DF090CV20	14.0	12.0	29,000	21,750	1000	3/4	3/8	3/4	3/8	3/4	3/8	0.063	A4TXV01
	E(C,H,M,U)1P43C	95G2DF110CV20	14.0	12.0	29,000	21,750	1000	3/4	3/8	3/4	3/8	3/4	3/8	0.063	A4TXV01
	E(C,H,M,U)1P43C	95G2UH090CV12	14.0	12.0	29,000	21,750	1000	3/4	3/8	3/4	3/8	3/4	3/8	0.063	A4TXV01
	E(C,M,U)1P30A	80G1DF045AE12	13.5	11.5	29,000	21,750	1000	3/4	3/8	3/4	3/8	3/4	3/8	0.063	A4TXV01
	E(C,M,U)1P30A	80G1UH045AE12	14.0	12.0	29,000	21,750	1000	3/4	3/8	3/4	3/8	3/4	3/8	0.063	A4TXV01
	E(C,M,U)1P30A	80G2UH070AV12	13.5	11.5	28,000	21,000	1000	3/4	3/8	3/4	3/8	3/4	3/8	0.063	A4TXV01
	E(C,M,U)1P30B	80G1DF070BE12	14.0	12.0	29,000	21,750	1000	3/4	3/8	3/4	3/8	3/4	3/8	0.063	A4TXV01
	E(C,M,U)1P30B	80G1DF090BE16	14.0	12.0	29,000	21,750	1000	3/4	3/8	3/4	3/8	3/4	3/8	0.063	A4TXV01
	E(C,M,U)1P30B	80G1UH070BE12	14.0	12.0	29,000	21,750	1000	3/4	3/8	3/4	3/8	3/4	3/8	0.063	A4TXV01
	E(C,M,U)1P30B	80G1UH090BE16	14.0	12.0	29,000	21,750	1000	3/4	3/8	3/4	3/8	3/4	3/8	0.063	A4TXV01
	E(C,M,U)1P30B	95G1DF045BE12	13.5	11.5	29,000	21,750	1000	3/4	3/8	3/4	3/8	3/4	3/8	0.063	A4TXV01
	E(C,M,U)1P30B	95G1DF070BE16	14.0	12.0	29,000	21,750	1000	3/4	3/8	3/4	3/8	3/4	3/8	0.063	A4TXV01
	E(C,M,U)1P30B	95G1UH045BE12	14.0	12.0	29,000	21,750	1000	3/4	3/8	3/4	3/8	3/4	3/8	0.063	A4TXV01
	E(C,M,U)1P30B	95G1UH070BE12	13.5	11.5	29,000	21,750	1000	3/4	3/8	3/4	3/8	3/4	3/8	0.063	A4TXV01
	E(C,M,U)1P30B	95G2DF045BV12	14.0	12.0	29,000	21,750	1000	3/4	3/8	3/4	3/8	3/4	3/8	0.063	A4TXV01

* = B or L B = Wire Guard

L = Louvered

Note:

¹ Certified in accordance with Unitary Air Conditioner Certification Program, which is based on AHRI Standard 210/240

² Required to achieve AHRI rating. If NA (Not Applicable) is in the piston column, then TXV is required.

³ A blower time delay relay is required to achieve AHRI rating. This feature is standard on all Allied Air Enterprises furnace and AH products.

⁴ For lines 25 ft or over, use 3/8"

⁵ For lines 25 ft or over, use 3/4"

Cooling Performance with Air Handlers and Furnaces 30, 36

Outdoor Model	Indoor Model	Variable Speed Furnace	SEER	EER	Rated ARI Capacity ¹ BTUH	Rated Sensible Capacity BTUH	CFM	Refrigerant Connection				Refrigerant Line Size		Indoor Expansion Device	
	Evaporator Coil or Air Handler ³							Outdoor		Indoor		Suction	Liquid	Piston ²	TXV
								Suction	Liquid	Suction	Liquid				
4AC13*30P-7,8	E(C,M,U)1P30B	95G2DF070BV16	14.0	12.0	29,000	21,750	1000	3/4	3/8	3/4	3/8	3/4	3/8	0.063	A4TXV01
	E(C,M,U)1P30B	95G2UH045BV12	14.0	12.0	29,000	21,750	1000	3/4	3/8	3/4	3/8	3/4	3/8	0.063	A4TXV01
	E(C,M,U)1P30B	95G2UH070BV12	14.0	12.0	29,000	21,750	1000	3/4	3/8	3/4	3/8	3/4	3/8	0.063	A4TXV01
	E(C,M,U)1P30C	95G1DF090CE16	13.5	11.5	29,000	21,750	1000	3/4	3/8	3/4	3/8	3/4	3/8	0.063	A4TXV01
	E(C,M,U)1P30C	95G1UH090CE16	13.5	11.5	29,000	21,750	1000	3/4	3/8	3/4	3/8	3/4	3/8	0.063	A4TXV01
	E(C,M,U)1P30C	95G2DF090CV20	14.0	12.0	29,000	21,750	1000	3/4	3/8	3/4	3/8	3/4	3/8	0.063	A4TXV01
	E(C,M,U)1P30C	95G2DF110CV20	14.0	12.0	29,000	21,750	1000	3/4	3/8	3/4	3/8	3/4	3/8	0.063	A4TXV01
	E(C,M,U)1P30C	95G2UH090CV12	14.0	12.0	29,000	21,750	1000	3/4	3/8	3/4	3/8	3/4	3/8	0.063	A4TXV01
4AC13*36P-7,8	BCS3M36C****P BCE3M36C****P		13.00	11.00	34,000	24800	1200	3/4	3/8	7/8	3/8	3/4 ⁵	3/8	0.072	A4TXV01
	BCS2M36V****P		13.50	11.00	34,000	24800	1200	3/4	3/8	7/8	3/8	3/4 ⁵	3/8	0.072	A4TXV01
	BCS3M36E****P		14.0	11.0	34,000	24800	1200	3/4	3/8	7/8	3/8	3/4 ⁵	3/8	0.072	A4TXV01
	E(C,H,M,U)1P36B	EFV12BC	13.50	11.00	34,000	24800	1200	3/4	3/8	7/8	3/8	3/4 ⁵	3/8	0.072	A4TXV01
	E(C,H,M,U)1P36B	80G1DF090BE16	13.50	11.00	34,000	24800	1200	3/4	3/8	7/8	3/8	3/4 ⁵	3/8	0.072	A4TXV01
	E(C,H,M,U)1P36C	80G1DF110CE20	13.50	11.00	34,000	24800	1200	3/4	3/8	7/8	3/8	3/4 ⁵	3/8	0.072	A4TXV01
	E(C,H,M,U)1P36B	80G1UH090BE16	13.50	11.00	34,000	24800	1200	3/4	3/8	7/8	3/8	3/4 ⁵	3/8	0.072	A4TXV01
	E(C,H,M,U)1P36C	80G1UH090CE20	13.50	11.00	34,000	24800	1200	3/4	3/8	7/8	3/8	3/4 ⁵	3/8	0.072	A4TXV01
	E(C,H,M,U)1P36C	80G1UH110CE20	13.50	11.00	34,000	24800	1200	3/4	3/8	7/8	3/8	3/4 ⁵	3/8	0.072	A4TXV01
	E(C,H,M,U)1P36C	80G2UH110CV20	13.50	11.00	34,000	24800	1200	3/4	3/8	7/8	3/8	3/4 ⁵	3/8	0.072	A4TXV01
	E(C,H,M,U)1P36C	95G1DF090CE16	13.50	11.00	34,000	24800	1200	3/4	3/8	7/8	3/8	3/4 ⁵	3/8	0.072	A4TXV01
	E(C,H,M,U)1P36C	95G1DF110CE20	13.50	11.00	34,000	24800	1200	3/4	3/8	7/8	3/8	3/4 ⁵	3/8	0.072	A4TXV01
	E(C,H,M,U)1P36C	95G2DF090CV20	13.50	11.00	34,000	24800	1200	3/4	3/8	7/8	3/8	3/4 ⁵	3/8	0.072	A4TXV01
	E(C,H,M,U)1P36C	95G2DF110CV20	13.50	11.00	34,000	24800	1200	3/4	3/8	7/8	3/8	3/4 ⁵	3/8	0.072	A4TXV01
	E(C,H,M,U)1P36C	95G1UH090CE16	13.50	11.00	34,000	24800	1200	3/4	3/8	7/8	3/8	3/4 ⁵	3/8	0.072	A4TXV01
	E(C,H,M,U)1P36C	95G1UH110CE20	13.50	11.00	34,000	24800	1200	3/4	3/8	7/8	3/8	3/4 ⁵	3/8	0.072	A4TXV01
	E(C,H,M,U)1P36C	95G2UH090CV12	13.50	11.00	34,000	24800	1200	3/4	3/8	7/8	3/8	3/4 ⁵	3/8	0.072	A4TXV01
	E(C,H,M,U)1P36C	95G2UH090CV20	13.50	11.00	34,000	24800	1200	3/4	3/8	7/8	3/8	3/4 ⁵	3/8	0.072	A4TXV01
	E(C,H,M,U)1P36C	95G2UH110CV20	13.50	11.00	34,000	24800	1200	3/4	3/8	7/8	3/8	3/4 ⁵	3/8	0.072	A4TXV01
	E(C,H,M,U)1P43B	EFV12BC	13.50	11.00	34,000	24800	1200	3/4	3/8	7/8	3/8	3/4 ⁵	3/8	0.072	A4TXV01
	E(C,H,M,U)1P43B	80G1DF090BE16	13.50	11.00	34,000	24800	1200	3/4	3/8	7/8	3/8	3/4 ⁵	3/8	0.072	A4TXV01
	E(C,H,M,U)1P43C	80G1DF110CE20	13.50	11.00	34,000	24800	1200	3/4	3/8	7/8	3/8	3/4 ⁵	3/8	0.072	A4TXV01
	E(C,H,M,U)1P43B	80G1UH090BE16	13.50	11.00	34,000	24800	1200	3/4	3/8	7/8	3/8	3/4 ⁵	3/8	0.072	A4TXV01

* = B or L B = Wire Guard

L = Louvered

Note:

¹ Certified in accordance with Unitary Air Conditioner Certification Program, which is based on AHRI Standard 210/240

² Required to achieve AHRI rating. If NA (Not Applicable) is in the piston column, then TXV is required.

³ A blower time delay relay is required to achieve AHRI rating. This feature is standard on all Allied Air Enterprises furnace and AH products.

⁴ For lines 25 ft or over, use 3/8"

⁵ For lines 25 ft or over, use 3/4"

Cooling Performance with Air Handlers and Furnaces 36, 42

Outdoor Model	Indoor Model	Variable Speed Furnace	SEER	EER	Rated ARI Capacity ¹ BTUH	Rated Sensible Capacity BTUH	CFM	Refrigerant Connection				Refrigerant Line Size		Indoor Expansion Device	
	Evaporator Coil or Air Handler ³							Outdoor		Indoor		Suction	Liquid	Piston ²	TXV
								Suction	Liquid	Suction	Liquid				
4AC13*36P-78	E(C,H,M,U)1P43C	80G1UH090CE20	13.50	11.00	34,000	24800	1200	3/4	3/8	7/8	3/8	3/4 ⁶	3/8	0.072	A4TXV01
	E(C,H,M,U)1P43C	80G1UH110CE20	13.50	11.00	34,000	24800	1200	3/4	3/8	7/8	3/8	3/4 ⁶	3/8	0.072	A4TXV01
	E(C,H,M,U)1P43C	80G2UH110CV20	13.50	11.00	34,000	24800	1200	3/4	3/8	7/8	3/8	3/4 ⁶	3/8	0.072	A4TXV01
	E(C,H,M,U)1P43C	95G1DF090CE16	13.50	11.00	34,000	24800	1200	3/4	3/8	7/8	3/8	3/4 ⁶	3/8	0.072	A4TXV01
	E(C,H,M,U)1P43C	95G1DF110CE20	13.50	11.00	34,000	24800	1200	3/4	3/8	7/8	3/8	3/4 ⁶	3/8	0.072	A4TXV01
	E(C,H,M,U)1P43C	95G2DF090CV20	13.50	11.00	34,000	24800	1200	3/4	3/8	7/8	3/8	3/4 ⁶	3/8	0.072	A4TXV01
	E(C,H,M,U)1P43C	95G2DF110CV20	13.50	11.00	34,000	24800	1200	3/4	3/8	7/8	3/8	3/4 ⁶	3/8	0.072	A4TXV01
	E(C,H,M,U)1P43C	95G1UH090CE16	13.50	11.00	34,000	24800	1200	3/4	3/8	7/8	3/8	3/4 ⁶	3/8	0.072	A4TXV01
	E(C,H,M,U)1P43C	95G1UH110CE20	13.50	11.00	34,000	24800	1200	3/4	3/8	7/8	3/8	3/4 ⁶	3/8	0.072	A4TXV01
	E(C,H,M,U)1P43C	95G2UH090CV12	13.50	11.00	34,000	24800	1200	3/4	3/8	7/8	3/8	3/4 ⁶	3/8	0.072	A4TXV01
	E(C,H,M,U)1P43C	95G2UH090CV20	13.50	11.00	34,000	24800	1200	3/4	3/8	7/8	3/8	3/4 ⁶	3/8	0.072	A4TXV01
	E(C,H,M,U)1P43C	95G2UH110CV20	13.50	11.00	34,000	24800	1200	3/4	3/8	7/8	3/8	3/4 ⁶	3/8	0.072	A4TXV01
	E(C,H,M,U)1P50C	EFV16CC	13.50	11.00	34,000	24800	1200	3/4	3/8	7/8	3/8	3/4 ⁶	3/8	0.072	A4TXV01
	E(C,H,M,U)1P50C	80G1DF110CE20	13.50	11.00	34,000	24800	1200	3/4	3/8	7/8	3/8	3/4 ⁶	3/8	0.072	A4TXV01
	E(C,H,M,U)1P50C	80G1UH090CE20	13.50	11.00	34,000	24800	1200	3/4	3/8	7/8	3/8	3/4 ⁶	3/8	0.072	A4TXV01
	E(C,H,M,U)1P50C	80G1UH110CE20	13.50	11.00	34,000	24800	1200	3/4	3/8	7/8	3/8	3/4 ⁶	3/8	0.072	A4TXV01
	E(C,H,M,U)1P50C	80G2UH110CV20	13.50	11.00	34,000	24800	1200	3/4	3/8	7/8	3/8	3/4 ⁶	3/8	0.072	A4TXV01
	E(C,H,M,U)1P50C	95G1DF090CE16	13.50	11.00	34,000	24800	1200	3/4	3/8	7/8	3/8	3/4 ⁶	3/8	0.072	A4TXV01
	E(C,H,M,U)1P50C	95G1DF110CE20	13.50	11.00	34,000	24800	1200	3/4	3/8	7/8	3/8	3/4 ⁶	3/8	0.072	A4TXV01
	E(C,H,M,U)1P50C	95G2DF090CV20	13.50	11.00	34,000	24800	1200	3/4	3/8	7/8	3/8	3/4 ⁶	3/8	0.072	A4TXV01
	E(C,H,M,U)1P50C	95G2DF110CV20	13.50	11.00	34,000	24800	1200	3/4	3/8	7/8	3/8	3/4 ⁶	3/8	0.072	A4TXV01
	E(C,H,M,U)1P50C	95G1UH090CE16	13.50	11.00	34,000	24800	1200	3/4	3/8	7/8	3/8	3/4 ⁶	3/8	0.072	A4TXV01
	E(C,H,M,U)1P50C	95G1UH110CE20	13.50	11.00	34,000	24800	1200	3/4	3/8	7/8	3/8	3/4 ⁶	3/8	0.072	A4TXV01
	E(C,H,M,U)1P50C	95G2UH090CV12	13.50	11.00	34,000	24800	1200	3/4	3/8	7/8	3/8	3/4 ⁶	3/8	0.072	A4TXV01
E(C,H,M,U)1P50C	95G2UH090CV20	13.50	11.00	34,000	24800	1200	3/4	3/8	7/8	3/8	3/4 ⁶	3/8	0.072	A4TXV01	
E(C,H,M,U)1P50C	95G2UH110CV20	13.50	11.00	34,000	24800	1200	3/4	3/8	7/8	3/8	3/4 ⁶	3/8	0.072	A4TXV01	
4AC13*42P-78	BCS3M42C****P BCE3M42C****P		13.0	11.0	40,000	29,200	1400	7/8	3/8	7/8	3/8	3/4 ⁶	3/8	0.075	A4TXV02
	BCE2M42V****P		13.5	11.5	40,000	29,200	1400	7/8	3/8	7/8	3/8	3/4 ⁶	3/8	0.075	A4TXV02
	BCE3M42E****P		14.0	11.0	40,000	29,200	1400	7/8	3/8	7/8	3/8	3/4 ⁶	3/8	0.075	A4TXV01

* = B or L B = Wire Guard

L = Louvered

Note:

¹ Certified in accordance with Unitary Air Conditioner Certification Program, which is based on AHRI Standard 210/240

² Required to achieve AHRI rating. If NA (Not Applicable) is in the piston column, then TXV is required.

³ A blower time delay relay is required to achieve AHRI rating. This feature is standard on all Allied Air Enterprises furnace and AH products.

⁴ For lines 25 ft or over, use 3/8"

⁵ For lines 25 ft or over, use 3/4"

Cooling Performance with Air Handlers and Furnaces 42

Outdoor Model	Indoor Model	Variable Speed Furnace	SEER	EER	Rated ARI Capacity ¹ BTUH	Rated Sensible Capacity BTUH	CFM	Refrigerant Connection				Refrigerant Line Size		Indoor Expansion Device	
	Evaporator Coil or Air Handler ³							Outdoor		Indoor		Suction	Liquid	Piston ²	TXV
								Suction	Liquid	Suction	Liquid				
4AC13*42P-7,8	BCS2M48V****P		13.5	11.5	40,000	29,200	1400	7/8	3/8	7/8	3/8	3/4 ⁶	3/8	0.075	A4TXV02
	E(C,H,M,U)1P43B	80G1DF090BE16	13.5	11.5	40,000	29,200	1400	7/8	3/8	7/8	3/8	3/4 ⁶	3/8	0.075	A4TXV02
	E(C,H,M,U)1P43B	80G1UH090BE16	13.5	11.5	40,000	29,200	1400	7/8	3/8	7/8	3/8	3/4 ⁶	3/8	0.075	A4TXV02
	E(C,H,M,U)1P43B	95G1DF070BE16	13.5	11.5	40,000	29,200	1400	7/8	3/8	7/8	3/8	3/4 ⁶	3/8	0.075	A4TXV02
	E(C,H,M,U)1P43C	80G1DF110CE20	13.5	11.5	40,000	29,200	1400	7/8	3/8	7/8	3/8	3/4 ⁶	3/8	0.075	A4TXV02
	E(C,H,M,U)1P43C	80G1UH090CE20	13.5	11.5	40,000	29,200	1400	7/8	3/8	7/8	3/8	3/4 ⁶	3/8	0.075	A4TXV02
	E(C,H,M,U)1P43C	80G1UH110CE20	13.5	11.5	40,000	29,200	1400	7/8	3/8	7/8	3/8	3/4 ⁶	3/8	0.075	A4TXV02
	E(C,H,M,U)1P43C	95G1DF090CE16	13.5	11.5	40,000	29,200	1400	7/8	3/8	7/8	3/8	3/4 ⁶	3/8	0.075	A4TXV02
	E(C,H,M,U)1P43C	95G1DF110CE20	13.5	11.5	40,000	29,200	1400	7/8	3/8	7/8	3/8	3/4 ⁶	3/8	0.075	A4TXV02
	E(C,H,M,U)1P43C	95G1UH090CE16	13.5	11.5	40,000	29,200	1400	7/8	3/8	7/8	3/8	3/4 ⁶	3/8	0.075	A4TXV02
	E(C,H,M,U)1P43C	95G1UH110CE20	13.5	11.5	40,000	29,200	1400	7/8	3/8	7/8	3/8	3/4 ⁶	3/8	0.075	A4TXV02
	E(C,H,M,U)1P43C	95G2DF090CV20	13.5	11.5	40,000	29,200	1400	7/8	3/8	7/8	3/8	3/4 ⁶	3/8	0.075	A4TXV02
	E(C,H,M,U)1P43C	95G2DF110CV20	13.5	11.5	40,000	29,200	1400	7/8	3/8	7/8	3/8	3/4 ⁶	3/8	0.075	A4TXV02
	E(C,H,M,U)1P43C	95G2UH090CV20	13.5	11.5	40,000	29,200	1400	7/8	3/8	7/8	3/8	3/4 ⁶	3/8	0.075	A4TXV02
	E(C,H,M,U)1P43C	95G2UH110CV20	13.5	11.5	40,000	29,200	1400	7/8	3/8	7/8	3/8	3/4 ⁶	3/8	0.075	A4TXV02
	E(C,H,U)1P49C	80G1DF110CE20	13.5	11.0	40,000	29,200	1400	7/8	3/8	7/8	3/8	3/4 ⁶	3/8	0.075	A4TXV02
	E(C,H,U)1P49C	80G1UH090CE20	13.5	11.0	40,000	29,200	1400	7/8	3/8	7/8	3/8	3/4 ⁶	3/8	0.075	A4TXV02
	E(C,H,U)1P49C	80G1UH110CE20	13.5	11.0	40,000	29,200	1400	7/8	3/8	7/8	3/8	3/4 ⁶	3/8	0.075	A4TXV02
	E(C,H,U)1P49C	80G2UH110CV20	13.5	11.0	40,000	29,200	1400	7/8	3/8	7/8	3/8	3/4 ⁶	3/8	0.075	A4TXV02
	E(C,H,U)1P49C	95G1DF090CE16	13.5	11.0	40,000	29,200	1400	7/8	3/8	7/8	3/8	3/4 ⁶	3/8	0.075	A4TXV02
	E(C,H,U)1P49C	95G1DF110CE20	13.5	11.0	40,000	29,200	1400	7/8	3/8	7/8	3/8	3/4 ⁶	3/8	0.075	A4TXV02
	E(C,H,U)1P49C	95G1UH090CE16	13.5	11.5	40,000	29,200	1400	7/8	3/8	7/8	3/8	3/4 ⁶	3/8	0.075	A4TXV02
	E(C,H,U)1P49C	95G1UH110CE20	13.5	11.0	40,000	29,200	1400	7/8	3/8	7/8	3/8	3/4 ⁶	3/8	0.075	A4TXV02
	E(C,H,U)1P49C	95G2DF090CV20	13.5	11.0	40,000	29,200	1400	7/8	3/8	7/8	3/8	3/4 ⁶	3/8	0.075	A4TXV02
	E(C,H,U)1P49C	95G2DF110CV20	13.5	11.0	40,000	29,200	1400	7/8	3/8	7/8	3/8	3/4 ⁶	3/8	0.075	A4TXV02
	E(C,H,U)1P49C	95G2UH090CV20	13.5	11.0	40,000	29,200	1400	7/8	3/8	7/8	3/8	3/4 ⁶	3/8	0.075	A4TXV02
	E(C,H,U)1P49C	95G2UH110CV20	13.5	11.0	40,000	29,200	1400	7/8	3/8	7/8	3/8	3/4 ⁶	3/8	0.075	A4TXV02
	E(C,M,U)1P50C	80G1DF110CE20	13.5	11.5	40,000	29,200	1400	7/8	3/8	7/8	3/8	3/4 ⁶	3/8	0.075	A4TXV02
	E(C,M,U)1P50C	80G1UH090CE20	13.5	11.5	40,000	29,200	1400	7/8	3/8	7/8	3/8	3/4 ⁶	3/8	0.075	A4TXV02
	E(C,M,U)1P50C	80G1UH110CE20	13.5	11.5	40,000	29,200	1400	7/8	3/8	7/8	3/8	3/4 ⁶	3/8	0.075	A4TXV02
E(C,M,U)1P50C	80G2UH110CV20	13.5	11.5	40,000	29,200	1400	7/8	3/8	7/8	3/8	3/4 ⁶	3/8	0.075	A4TXV02	

* = B or L B = Wire Guard L = Louvered

Note:

¹ Certified in accordance with Unitary Air Conditioner Certification Program, which is based on AHRI Standard 210/240

² Required to achieve AHRI rating. If NA (Not Applicable) is in the piston column, then TXV is required.

³ A blower time delay relay is required to achieve AHRI rating. This feature is standard on all Allied Air Enterprises furnace and AH products.

⁴ For lines 25 ft or over, use 3/8"

⁵ For lines 25 ft or over, use 3/4"

Cooling Performance with Air Handlers and Furnaces 42, 48, 60

Outdoor Model	Indoor Model	Variable Speed Furnace	SEER	EER	Rated ARI Capacity ¹ BTUH	Rated Sensible Capacity BTUH	CFM	Refrigerant Connection				Refrigerant Line Size		Indoor Expansion Device	
	Evaporator Coil or Air Handler ³							Outdoor		Indoor		Suction	Liquid	Piston ²	TXV
								Suction	Liquid	Suction	Liquid				
4AC13*42P-7,8	E(C,M,U)1P50C	95G1DF090CE16	13.5	11.5	40,000	29,200	1400	7/8	3/8	7/8	3/8	3/4 ⁴	3/8	0.075	A4TXV02
	E(C,M,U)1P50C	95G1DF110CE20	13.5	11.5	40,000	29,200	1400	7/8	3/8	7/8	3/8	3/4 ⁴	3/8	0.075	A4TXV02
	E(C,M,U)1P50C	95G1UH090CE16	13.5	11.5	40,000	29,200	1400	7/8	3/8	7/8	3/8	3/4 ⁴	3/8	0.075	A4TXV02
	E(C,M,U)1P50C	95G1UH110CE20	13.5	11.5	40,000	29,200	1400	7/8	3/8	7/8	3/8	3/4 ⁴	3/8	0.075	A4TXV02
	E(C,M,U)1P50C	95G2DF090CV20	13.5	11.5	40,000	29,200	1400	7/8	3/8	7/8	3/8	3/4 ⁴	3/8	0.075	A4TXV02
	E(C,M,U)1P50C	95G2DF110CV20	13.5	11.5	40,000	29,200	1400	7/8	3/8	7/8	3/8	3/4 ⁴	3/8	0.075	A4TXV02
	E(C,M,U)1P50C	95G2UH090CV20	13.5	11.5	40,000	29,200	1400	7/8	3/8	7/8	3/8	3/4 ⁴	3/8	0.075	A4TXV02
	E(C,M,U)1P50C	95G2UH110CV20	13.5	11.5	40,000	29,200	1400	7/8	3/8	7/8	3/8	3/4 ⁴	3/8	0.075	A4TXV02
4AC13*48P-7,8	BCS3M48C****P BCE3M48C****P		13.00	11.00	47,000	34300	1600	7/8	3/8	7/8	3/8	7/8	3/8	0.082	A4TXV02
	BCS2M48V****P		13.50	11.00	47,000	34300	1600	7/8	3/8	7/8	3/8	7/8	3/8	0.082	A4TXV02
	BCS3M48E****P		14.0	11.0	47,000	34300	1600	7/8	3/8	7/8	3/8	7/8	3/8	0.082	A4TXV02
4AC13*60P-7,8	BCS3M60C****P BCE3M60C****P		13.00	11.00	57,000	41000	1800	7/8	3/8	7/8	3/8	7/8 ⁵	3/8	0.090	A4TXV02
	BCS2M60V****P		13.50	11.00	57,000	41000	1800	7/8	3/8	7/8	3/8	7/8 ⁵	3/8	0.090	A4TXV02
	BCS3M60E****P		13.5	11.0	57,000	41000	1800	7/8	3/8	7/8	3/8	7/8 ⁵	3/8	0.090	A4TXV02

* = B or L B = Wire Guard L = Louvered

Note:

¹ Certified in accordance with Unitary Air Conditioner Certification Program, which is based on AHRI Standard 210/240

² Required to achieve AHRI rating. If NA (Not Applicable) is in the piston column, then TXV is required.

³ A blower time delay relay is required to achieve AHRI rating. This feature is standard on all Allied Air Enterprises furnace and AH products.

⁴ For lines 25 ft or over, use 3/8"

⁵ For lines 25 ft or over, use 3/4"

Cooling Performance — Extended Ratings

Outdoor Model	Indoor Model Piston or Field Installed TXV	Indoor Temp DB/WB °F	Outdoor Temp - DB°F														
			65			82			95			105			115		
			Btuh	S/T	kW	Btuh	S/T	kW	Btuh	S/T	kW	Btuh	S/T	kW	Btuh	S/T	kW
4AC13*18P-7.8	E*1P19	85/72	19,900	0.67	1.49	19,000	0.71	1.61	18,500	0.74	1.71	17,400	0.76	1.78	16,300	0.77	1.38
		80/67	18,800	0.69	1.38	18,300	0.73	1.74	18,000	0.76	1.64	16,700	0.78	2.19	15,300	0.80	1.33
		75/63	17,400	0.74	1.33	16,900	0.78	1.47	16,700	0.81	1.58	15,500	0.83	1.65	14,200	0.85	1.28
		75/57	16,400	0.83	1.30	16,100	0.88	1.44	16,000	0.91	1.55	14,900	0.93	1.61	13,600	0.95	1.25
4AC13*24P-7.8	E*1P24	85/72	23,200	0.65	1.66	23,100	0.70	1.90	23,100	0.74	2.08	22,300	0.76	2.20	21,400	0.77	1.90
		80/67	22,900	0.69	1.65	23,000	0.73	2.03	23,000	0.76	2.06	21,700	0.79	2.51	20,300	0.81	1.69
		75/63	22,700	0.74	1.65	22,000	0.78	1.84	21,400	0.81	1.99	20,100	0.83	2.06	18,800	0.85	1.76
		75/57	22,300	0.83	1.64	21,500	0.88	1.82	20,800	0.91	1.95	19,500	0.93	2.02	18,200	0.95	1.72
4AC13*30P-7.8	E*1P29	85/72	31,900	0.66	2.14	30,700	0.70	2.46	29,700	0.73	2.72	27,900	0.75	2.81	26,200	0.76	3.02
		80/67	30,100	0.68	2.12	28,900	0.72	2.03	28,000	0.75	2.61	26,300	0.77	2.51	24,700	0.78	2.91
		75/63	27,900	0.79	2.11	26,800	0.80	2.34	25,900	0.80	2.51	24,300	0.82	2.60	22,800	0.84	2.80
		75/57	27,100	0.82	2.07	26,000	0.87	2.29	25,100	0.90	2.46	23,600	0.92	2.55	22,200	0.94	2.74
4AC13*36P-7.8	E*1P36	85/72	42,100	0.61	2.40	39,890	0.64	2.86	38,200	0.67	3.22	35,650	0.70	3.61	33,100	0.73	3.99
		80/67	39,900	0.68	2.38	37,010	0.73	2.85	34,800	0.76	3.21	32,150	0.79	3.58	29,500	0.81	3.95
		75/63	37,900	0.71	2.36	34,727	0.75	2.82	32,300	0.78	3.17	29,600	0.82	3.53	26,900	0.86	3.88
		75/57	35,800	1.00	2.33	32,570	1.00	2.77	30,100	1.00	3.11	27,150	1.00	3.47	24,200	1.00	3.82
4AC13*42P-7.8	E*1P43	85/72	46,800	0.65	1.66	44,900	0.68	2.91	43,500	0.71	3.86	41,000	0.73	4.02	38,500	0.74	6.17
		80/67	44,500	0.67	1.65	42,500	0.70	2.03	41,000	0.73	3.73	39,600	0.75	2.51	38,200	0.77	6.13
		75/63	44,200	0.68	1.65	40,600	0.74	2.75	37,900	0.78	3.59	35,600	0.80	3.72	33,400	0.82	5.71
		75/57	40,800	0.71	1.64	38,600	0.80	2.70	36,800	0.87	3.51	34,600	0.89	3.64	32,400	0.91	5.60
4AC13*48P-7.8	E*1P49	85/72	61,100	0.63	3.56	57,870	0.65	4.50	55,400	0.66	4.57	52,000	0.69	5.03	48,600	0.71	5.48
		80/67	56,800	0.69	3.49	53,230	0.71	4.06	50,500	0.73	4.50	46,800	0.76	4.95	43,100	0.79	5.39
		75/63	53,300	0.72	3.44	49,447	0.75	4.01	46,500	0.77	4.44	42,800	0.80	4.92	39,100	0.83	5.39
		75/57	47,000	1.00	3.39	43,713	1.00	3.95	41,200	1.00	4.38	38,500	1.00	4.85	35,800	1.00	5.31
4AC13*60P-7.8	E*1P49	85/72	69,800	0.61	4.02	66,457	0.63	4.75	63,900	0.64	5.30	59,950	0.67	5.87	56,000	0.69	6.44
		80/67	65,400	0.68	3.96	61,490	0.70	4.72	58,500	0.71	5.30	54,600	0.74	5.83	50,700	0.77	6.36
		75/63	61,400	0.71	3.90	56,923	0.73	4.59	53,500	0.75	5.12	49,650	0.78	5.70	45,800	0.81	6.27
		75/57	45,400	1.00	3.83	46,760	1.00	4.54	47,800	1.00	5.09	45,600	1.00	5.67	43,400	1.00	6.24

Note: Extended data shown is actual for models listed and typical for all AHRI matches.

* = B or L B = Wire Guard
L = Louvered

Accessories

Description	Where Used	Catalog Number
Crankcase Heater	18, 24, 30, 36	93M04
Crankcase Heater	42, 48, 60	93M05
Hard Start Kit	18	10J42
Hard Start kit	24, 30, 36, 42, 48, 60	88M91
Compressor Low Ambient Kit	18, 24, 30, 36, 42, 48, 60	34M72
Sound Blanket	18, 24, 30, 36	14W00
	42, 48, 60	14W01
Short Cycle Protector	18, 24, 30, 36, 42, 48, 60	47J27
Freezestat	3/8" tubing	93G35
Freezestat	5/8" tubing	50A93
Time Delay Relay	18, 24, 30, 36, 42, 48, 60	58M81
Loss of Charge Kit	18, 24, 30, 36, 42, 48, 60	84M23
TXV Kit	18 - 36	A4TXV01
TXV Kit	42 - 60	A4TXV02



1-800-448-5872

All specifications and illustrations subject to change without notice and without incurring obligations.