



COOLING CAPACITY:  
34,000 - 56,000 BTU/H

# ASXC18

HIGH-EFFICIENCY,  
COMFORTNET-COMPATIBLE,  
SPLIT-SYSTEM AIR CONDITIONER  
UP TO 19 SEER



### Contents

Nomenclature.....	2
Product Specifications.....	3
Expanded Cooling Data.....	4
AHRI Ratings .....	16
Dimensions .....	22
Wiring Diagram.....	23
Accessories .....	24

### Standard Features

- Two-Stage Copeland® UltraTech scroll compressor
- High-density foam compressor sound blanket
- ComfortNet™ Communications System compatible
- Expanded ComfortAlert diagnostics built in
- Set-up capable with two low-voltage wires to outdoor unit
- Diagnostic indicator lights and storage of six fault codes
- Color-coded terminal strip for non-communicating set-up
- Fully charged for 15' of tubing length
- Factory-installed filter drier
- Coil and ambient temperature sensors
- Sweat connection service valves with easy access to gauge ports
- AHRI Certified; ETL Listed

### Cabinet Features

- Amana® brand sound control top design
- Wire fan discharge grille
- Steel louver coil guard
- Baked-on powder-paint finish
- Rust-resistant coated screws
- Compact footprint
- Top and side maintenance access
- Single-panel access to controls with space provided for field-installed accessories
- When properly anchored, meets the 2010 Florida Building Code unit integrity requirements for hurricane-type winds (Anchor bracket kits available.)



\* Complete warranty details available from your local dealer or at [www.amana-hac.com](http://www.amana-hac.com). To receive the Lifetime Unit Replacement Limited Warranty (good for as long as you own your home) and 10-Year Parts Limited Warranty, online registration must be completed within 60 days of installation. Online registration is not required in California or Québec.

	A	S	X	C	18	036	1	A	A	
	1	2	3	4	5,6	7,8,9	10	11	12	
<b>Brand</b>	A Amana® Brand									<b>Engineering *</b>
										Minor Revision
<b>Product Category</b>	S Split System									<b>Engineering *</b>
										Major Revision
<b>Unit Type</b>	C Condenser R-22									<b>Electrical</b>
	X Condenser R-410A									1 208/230 V, 1 Phase, 60 Hz
	H Heat Pump R-22									2 220/240 V, 1 Phase, 50 Hz
	Z Heat Pump R-410A									3 208/230 V, 3 Phase, 60 Hz
										4 460 V, 3 Phase, 60 Hz
										5 380/415 V, 3 Phase, 50 Hz
<b>Communication Feature</b>	C ComfortNet 4-wire communications ready									<b>Nominal Capacity</b>
										018 1½ Tons 048 4 Tons
										024 2 Tons 060 5 Tons
										030 2½ Tons 090 7½ tons
										036 3 Tons 120 10 Tons
										042 3½ Tons
<b>Efficiency</b>	13 13 SEER 16 16 SEER									
	14 14 SEER 18 18 SEER									

\* Neither used for order entry or inventory management.



	ASXC18 0361A	ASXC18 0481A	ASXC18 0601A
<b>COOLING CAPACITY</b>			
Nominal Cooling (BTU/h)	35,000	47,000	57,000
Decibels	71	72	74
<b>COMPRESSOR</b>			
RLA	15.3	21.2	27.1
LRA	83	104	152.9
<b>CONDENSER FAN MOTOR</b>			
Horsepower (RPM)	⅓	⅓	⅓
FLA	2.80	2.80	2.80
<b>REFRIGERATION SYSTEM</b>			
Refrigerant Line Size <sup>1</sup>			
Liquid Line Size ("O.D.)	⅜"	⅜"	⅜"
Suction Line Size ("O.D.)	⅞"	1⅞"	1⅞"
Refrigerant Connection Size			
Liquid Valve Size ("O.D.)	⅜"	⅜"	⅜"
Suction Valve Size ("O.D.)	⅞"	⅞"	⅞"
Valve Connection Type	Sweat	Sweat	Sweat
Refrigerant Charge	187	262	262
Expansion Device	TXV	TXV	TXV
Superheat at Service Valve	7-9°F	7-9°F	7-9°F
Subcooling at Service Valve	5-7°F	5-7°F	5-7°F
<b>ELECTRICAL DATA</b>			
Voltage-Phase-Hz	208/230-1-60	208/230-1-60	208/230-1-60
Minimum Circuit Ampacity <sup>1</sup>	21.9	29.3	34.8
Max. Overcurrent Protection <sup>2</sup>	35	50	60
Min / Max Volts	197 / 253	197 / 253	197 / 253
Electrical Conduit Size	½" or ¾"	½" or ¾"	½" or ¾"
<b>EQUIPMENT WEIGHT (LBS)</b>			
	206	268	274
<b>SHIP WEIGHT (LBS)</b>			
	228	290	296

<sup>1</sup> Wire size should be determined in accordance with National Electrical Codes; extensive wire runs will require larger wire sizes

<sup>2</sup> Must use time-delay fuses or HACR-type circuit breakers of the same size as noted.

**NOTES**

- Always check the S&R plate for electrical data on the unit being installed.
- Installer will need to supply ⅞" to 1⅞" adapters for suction line connections.
- Unit is charged with refrigerant for 15' of ⅜" liquid line. System charge must be adjusted per Installation Instructions Final Charge Procedure.
- Installation of these units that require a TXV Kit to be installed on the indoor coil.
- PLEASE NOTE: the specified TXV is determined by the outdoor unit, not the indoor coil.

IDB	AIRFLOW	OUTDOOR AMBIENT TEMPERATURE												ENTERING INDOOR WET BULB TEMPERATURE											
		65°F				75°F				85°F				95°F				105°F				115°F			
		59	63	67	71	59	63	67	71	59	63	67	71	59	63	67	71	59	63	67	71	59	63	67	71
70	MBh	25.3	26.2	28.8	-	24.7	25.6	28.1	-	24.1	25.0	27.4	-	23.6	24.4	26.8	-	22.4	23.2	25.4	-	20.7	21.5	23.5	-
	S/T	0.76	0.63	0.44	-	0.79	0.66	0.45	-	0.81	0.67	0.47	-	0.83	0.70	0.48	-	0.86	0.72	0.50	-	0.87	0.73	0.50	-
	ΔT	19	16	12	-	19	17	13	-	19	17	13	-	19	17	13	-	19	17	13	-	18	15	12	-
	kW	1.30	1.33	1.38	-	1.41	1.45	1.50	-	1.51	1.55	1.60	-	1.60	1.63	1.69	-	1.67	1.71	1.77	-	1.73	1.77	1.84	-
	Amps	5.3	5.5	5.7	-	5.8	5.9	6.1	-	6.3	6.5	6.7	-	6.7	6.9	7.1	-	7.2	7.4	7.6	-	7.6	7.8	8.1	-
	HI PR	210	226	229	-	237	255	259	-	270	290	295	-	308	331	335	-	332	357	362	-	394	423	429	-
	Lo PR	124	128	140	-	128	132	144	-	132	136	149	-	135	140	153	-	138	143	156	-	142	146	159	-
	MBh	24.6	25.5	27.9	-	24.0	24.9	27.3	-	23.4	24.3	26.6	-	22.9	23.7	26.0	-	21.7	22.5	24.7	-	20.1	20.9	22.9	-
	S/T	0.72	0.60	0.42	-	0.75	0.63	0.43	-	0.77	0.64	0.44	-	0.79	0.66	0.46	-	0.82	0.69	0.48	-	0.83	0.69	0.48	-
	ΔT	20	17	13	-	20	17	13	-	20	17	13	-	20	18	13	-	20	17	13	-	19	16	12	-
kW	1.29	1.32	1.37	-	1.40	1.43	1.48	-	1.50	1.53	1.59	-	1.58	1.62	1.68	-	1.65	1.69	1.75	-	1.72	1.76	1.82	-	
Amps	5.3	5.4	5.6	-	5.7	5.9	6.1	-	6.2	6.4	6.6	-	6.7	6.8	7.1	-	7.1	7.3	7.5	-	7.6	7.7	8.0	-	
HI PR	208	224	227	-	235	253	256	-	267	288	292	-	305	327	332	-	329	354	359	-	390	419	425	-	
Lo PR	123	127	138	-	126	130	142	-	131	135	147	-	134	138	151	-	137	141	154	-	140	145	158	-	
MBh	22.7	23.5	25.8	-	22.2	23.0	25.2	-	21.6	22.4	24.6	-	21.1	21.9	24.0	-	20.1	20.8	22.8	-	18.6	19.3	21.1	-	
S/T	0.70	0.58	0.40	-	0.72	0.60	0.42	-	0.74	0.62	0.43	-	0.77	0.64	0.44	-	0.79	0.66	0.46	-	0.80	0.67	0.46	-	
ΔT	20	18	13	-	20	18	13	-	20	18	13	-	21	18	14	-	20	18	13	-	19	16	12	-	
kW	1.28	1.31	1.36	-	1.39	1.42	1.47	-	1.48	1.52	1.57	-	1.57	1.60	1.66	-	1.64	1.68	1.74	-	1.70	1.74	1.80	-	
Amps	5.2	5.4	5.5	-	5.7	5.8	6.0	-	6.2	6.3	6.5	-	6.6	6.8	7.0	-	7.1	7.2	7.5	-	7.5	7.7	7.9	-	
HI PR	206	221	225	-	233	250	254	-	265	285	289	-	302	324	329	-	326	350	355	-	386	415	421	-	
Lo PR	122	125	137	-	125	129	141	-	129	133	146	-	133	137	150	-	135	140	153	-	139	143	156	-	

75	MBh	25.8	26.5	28.7	30.8	25.2	25.9	28.0	30.1	24.6	25.3	27.4	29.4	24.0	24.7	26.7	28.7	22.8	23.4	25.4	27.2	21.1	21.7	23.5	25.2
	S/T	0.86	0.77	0.58	0.38	0.89	0.80	0.60	0.39	0.92	0.82	0.62	0.40	0.95	0.85	0.64	0.41	0.98	0.88	0.66	0.43	0.99	0.89	0.67	0.43
	ΔT	22	20	17	11	22	20	17	12	22	20	17	12	22	21	17	12	22	20	17	12	21	19	16	11
	kW	1.30	1.33	1.38	1.43	1.41	1.45	1.50	1.55	1.51	1.55	1.60	1.66	1.60	1.63	1.69	1.75	1.67	1.71	1.77	1.83	1.73	1.77	1.84	1.90
	Amps	5.3	5.5	5.7	5.9	5.8	5.9	6.1	6.4	6.3	6.5	6.7	6.9	6.7	6.9	7.1	7.4	7.2	7.4	7.6	7.9	7.6	7.8	8.1	8.4
	HI PR	210	226	229	234	237	255	259	265	270	290	295	301	308	331	335	343	332	357	362	370	394	423	429	439
	Lo PR	124	128	140	149	128	132	144	153	132	136	149	158	135	140	153	162	138	143	156	166	142	146	159	170
	MBh	25.0	25.7	27.9	29.9	24.4	25.1	27.2	29.2	23.8	24.5	26.6	28.5	23.3	23.9	25.9	27.8	22.1	22.8	24.6	26.4	20.5	21.1	22.8	24.5
	S/T	0.82	0.74	0.56	0.36	0.85	0.76	0.58	0.37	0.87	0.78	0.59	0.38	0.90	0.81	0.61	0.39	0.94	0.84	0.63	0.41	0.94	0.84	0.64	0.41
	ΔT	23	21	17	12	23	21	17	12	23	21	18	12	23	22	18	12	23	21	17	12	22	20	16	11
kW	1.29	1.32	1.37	1.42	1.40	1.43	1.48	1.54	1.50	1.53	1.59	1.64	1.58	1.62	1.68	1.74	1.65	1.69	1.75	1.82	1.72	1.76	1.82	1.88	
Amps	5.3	5.4	5.6	5.8	5.7	5.9	6.1	6.3	6.2	6.4	6.6	6.9	6.7	6.8	7.1	7.4	7.1	7.3	7.5	7.8	7.6	7.7	8.0	8.3	
HI PR	208	224	227	232	235	253	256	262	267	288	292	298	305	327	332	339	329	354	359	367	390	419	425	435	
Lo PR	123	127	138	147	126	130	142	152	131	135	147	157	134	138	151	161	137	141	154	164	140	145	158	168	
MBh	23.1	23.8	25.7	27.6	22.5	23.2	25.1	27.0	22.0	22.7	24.5	26.3	21.5	22.1	23.9	25.7	20.4	21.0	22.7	24.4	18.9	19.5	21.1	22.6	
S/T	0.79	0.71	0.54	0.35	0.82	0.74	0.56	0.36	0.84	0.75	0.57	0.37	0.87	0.78	0.59	0.38	0.90	0.81	0.61	0.39	0.91	0.81	0.62	0.40	
ΔT	23	22	18	12	24	22	18	12	24	22	18	12	24	22	18	12	24	22	18	12	22	20	17	11	
kW	1.28	1.31	1.36	1.40	1.39	1.42	1.47	1.52	1.48	1.52	1.57	1.63	1.57	1.60	1.66	1.72	1.64	1.68	1.74	1.80	1.70	1.74	1.80	1.87	
Amps	5.2	5.4	5.5	5.8	5.7	5.8	6.0	6.2	6.2	6.3	6.5	6.8	6.6	6.8	7.0	7.3	7.1	7.2	7.5	7.8	7.5	7.7	7.9	8.2	
HI PR	206	221	225	230	233	250	254	259	265	285	289	295	302	324	329	336	326	350	355	363	386	415	421	430	
Lo PR	122	125	137	146	125	129	141	150	129	133	146	155	133	137	150	159	135	140	153	162	139	143	156	166	

IDB = Entering Indoor Dry Bulb Temperature  
 High and low pressures are measured at the liquid and suction service valves.  
 Shaded area is ACCA (TVA) conditions  
 kW = Total system power  
 Amps = outdoor unit amps (comp.+fan)

IDB	AIRFLOW	OUTDOOR AMBIENT TEMPERATURE												ENTERING INDOOR WET BULB TEMPERATURE											
		65°F				75°F				85°F				95°F				105°F				115°F			
		59	63	67	71	59	63	67	71	59	63	67	71	59	63	67	71	59	63	67	71	59	63	67	71
80	MBh	26.2	26.8	28.6	30.6	25.6	26.2	28.0	29.9	25.0	25.5	27.3	29.2	24.4	24.9	26.6	28.5	23.2	23.7	25.3	27.0	21.5	21.9	23.4	25.0
	S/T	0.95	0.89	0.72	0.54	1.00	0.92	0.75	0.56	1.00	0.94	0.77	0.57	1.00	1.00	0.79	0.59	1.00	1.00	0.82	0.61	1.00	1.00	0.83	0.62
	ΔT	25	23	20	16	25	24	21	17	25	24	21	17	24	25	21	17	23	23	21	16	21	22	19	15
	kW	1.30	1.33	1.38	1.43	1.41	1.45	1.50	1.55	1.51	1.55	1.60	1.66	1.60	1.63	1.69	1.75	1.67	1.71	1.77	1.83	1.73	1.77	1.84	1.90
	Amps	5.3	5.5	5.7	5.9	5.8	5.9	6.1	6.4	6.3	6.5	6.7	6.9	6.7	6.9	7.1	7.4	7.2	7.4	7.6	7.9	7.6	7.8	8.1	8.4
	HI PR	210	226	229	234	237	255	259	265	270	290	295	301	308	331	335	343	332	357	362	370	394	423	429	439
	Lo PR	124	128	140	149	128	132	144	153	132	136	149	158	135	140	153	162	138	143	156	166	142	146	159	170
	MBh	25.4	26.0	27.8	29.7	24.9	25.4	27.1	29.0	24.3	24.8	26.5	28.3	23.7	24.2	25.8	27.6	22.5	23.0	24.6	26.2	20.8	21.3	22.7	24.3
	S/T	0.90	0.85	0.69	0.51	0.93	0.88	0.71	0.53	0.96	0.90	0.73	0.55	0.99	0.93	0.76	0.56	1.00	0.96	0.78	0.59	1.00	0.97	0.79	0.59
	ΔT	26	25	21	17	26	25	22	17	26	25	22	17	26	25	22	17	25	25	21	17	23	23	20	16
kW	1.29	1.32	1.37	1.42	1.40	1.43	1.48	1.54	1.50	1.53	1.59	1.64	1.58	1.62	1.68	1.74	1.65	1.69	1.75	1.82	1.72	1.76	1.82	1.88	
Amps	5.3	5.4	5.6	5.8	5.7	5.9	6.1	6.3	6.2	6.4	6.6	6.9	6.7	6.8	7.1	7.4	7.1	7.3	7.5	7.8	7.6	7.7	8.0	8.3	
HI PR	208	224	227	232	235	253	256	262	267	288	292	298	305	327	332	339	329	354	359	367	390	419	425	435	
Lo PR	123	127	138	147	126	130	142	152	131	135	147	157	134	138	151	161	137	141	154	164	140	145	158	168	
MBh	23.5	24.0	25.6	27.4	22.9	23.4	25.0	26.8	22.4	22.9	24.5	26.1	21.9	22.3	23.9	25.5	20.8	21.2	22.7	24.2	19.2	19.6	21.0	22.4	
S/T	0.87	0.82	0.66	0.50	0.90	0.85	0.69	0.51	0.92	0.87	0.71	0.53	0.95	0.89	0.73	0.54	0.99	0.93	0.76	0.56	1.00	0.94	0.76	0.57	
ΔT	26	25	22	17	26	25	22	18	26	25	22	18	27	26	22	18	26	25	22	17	25	24	20	16	
kW	1.28	1.31	1.36	1.40	1.39	1.42	1.47	1.52	1.48	1.52	1.57	1.63	1.57	1.60	1.66	1.72	1.64	1.68	1.74	1.80	1.70	1.74	1.80	1.87	
Amps	5.2	5.4	5.5	5.8	5.7	5.8	6.0	6.2	6.2	6.3	6.5	6.8	6.6	6.8	7.0	7.3	7.1	7.2	7.5	7.8	7.5	7.7	7.9	8.2	
HI PR	206	221	225	230	233	250	254	259	265	285	289	295	302	324	329	336	326	350	355	363	386	415	421	430	
Lo PR	122	125	137	146	125	129	141	150	129	133	146	155	133	137	150	159	135	140	153	162	139	143	156	166	

85	MBh	26.7	27.2	28.5	30.4	26.0	26.6	27.8	29.7	25.4	25.9	27.1	29.0	24.8	25.3	26.5	28.3	23.6	24.0	25.2	26.8	21.8	22.3	23.3	24.9
	S/T	0.99	0.96	0.86	0.70	1.00	0.99	0.89	0.73	1.00	1.00	0.92	0.74	1.00	1.00	0.95	0.77	1.00	1.00	0.98	0.80	1.00	1.00	0.99	0.80
	ΔT	26	26	24	21	26	26	25	21	25	26	25	21	25	25	25	21	23	24	24	21	22	22	23	20
	kW	1.30	1.33	1.38	1.43	1.41	1.45	1.50	1.55	1.51	1.55	1.60	1.66	1.60	1.63	1.69	1.75	1.67	1.71	1.77	1.83	1.73	1.77	1.84	1.90
	Amps	5.3	5.5	5.7	5.9	5.8	5.9	6.1	6.4	6.3	6.5	6.7	6.9	6.7	6.9	7.1	7.4	7.2	7.4	7.6	7.9	7.6	7.8	8.1	8.4
	HI PR	210	226	229	234	237	255	259	265	270	290	295	301	308	331	335	343	332	357	362	370	394	423	429	439
	Lo PR	124	128	140	149	128	132	144	153	132	136	149	158	135	140	153	162	138	143	156	166	142	146	159	170
	MBh	25.9	26.4	27.6	29.5	25.3	25.8	27.0	28.8	24.7	25.2	26.4	28.1	24.1	24.6	25.7	27.4	22.9	23.3	24.4	26.1	21.2	21.6	22.6	24.1
	S/T	0.95	0.91	0.82	0.67	0.98	0.95	0.85	0.69	1.00	0.97	0.88	0.71	1.00	1.00	0.90	0.73	1.00	1.00	0.94	0.76	1.00	1.00	0.95	0.77
	ΔT	27	27	25	22	28	27	26	22	28	27	26	22	27	27	26	22	25	26	26	22	24	24	24	21
kW	1.29	1.32	1.37	1.42	1.40	1.43	1.48	1.54	1.50	1.53	1.59	1.64	1.58	1.62	1.68	1.74	1.65	1.69	1.75	1.82	1.72	1.76	1.82	1.88	
Amps	5.3	5.4	5.6	5.8	5.7	5.9	6.1	6.3	6.2	6.4	6.6	6.9	6.7	6.8	7.1	7.4	7.1	7.3	7.5	7.8	7.6	7.7	8.0	8.3	
HI PR	208	224	227	232	235	253	256	262	267	288	292	298	305	327	332	339	329	354	359	367	390	419	425	435	
Lo PR	123	127	138	147	126	130	142	152	131	135	147	157	134	138	151	161	137	141	154	164	140	145	158	168	
MBh	23.9	24.4	25.5	27.2	23.3	23.8	24.9	26.6	22.8	23.2	24.3	26.0	22.2	22.7	23.7	25.3	21.1	21.5	22.5	24.1	19.6	19.9	20.9	22.3	
S/T	0.91	0.88	0.79	0.64	0.94	0.91	0.82	0.67	0.97	0.93	0.84	0.68	1.00	0.97	0.87	0.71	1.00	1.00	0.90	0.73	1.00	1.00	0.91	0.74	
ΔT	27.8	27	26	22	28	28	26	23	28	28	26	23	28	28	26	23	27	27	26	23	25	25	24	21	
kW	1.28	1.31	1.36	1.40	1.39	1.42	1.47	1.52	1.48	1.52	1.57	1.63	1.57	1.60	1.66	1.72	1.64	1.68	1.74	1.80	1.70	1.74	1.80	1.87	
Amps	5.2	5.4	5.5	5.8	5.7	5.8	6.0	6.2	6.2	6.3	6.5	6.8	6.6	6.8	7.0	7.3	7.1	7.2	7.5	7.8	7.5	7.7	7.9	8.2	
HI PR	206	221	225	230	233	250	254	259	265	285	289	295	302	324	329	336	326	350	355	363	386	415	421	430	
Lo PR	122	125	137	146	125	129	141	150	129	133	146	155	133	137	150	159	135	140	153	162	139	143	156	166	

IDB = Entering Indoor Dry Bulb Temperature  
 High and low pressures are measured at the liquid and suction service valves.  
 Shaded area is AHRI (TVA) conditions  
 kW = Total system power  
 Amps = outdoor unit amps (comp.+fan)

IDB	AIRFLOW	OUTDOOR AMBIENT TEMPERATURE												ENTERING INDOOR WET BULB TEMPERATURE											
		65°F				75°F				85°F				95°F				105°F				115°F			
		59	63	67	71	59	63	67	71	59	63	67	71	59	63	67	71	59	63	67	71	59	63	67	71
70	MBh	36.7	38.1	41.7	-	35.9	37.2	40.7	-	35.0	36.3	39.8	-	34.2	35.4	38.8	-	32.4	33.6	36.8	-	30.1	31.2	34.1	-
	S/T	0.74	0.62	0.43	-	0.76	0.64	0.44	-	0.78	0.65	0.45	-	0.81	0.68	0.47	-	0.84	0.70	0.49	-	0.85	0.71	0.49	-
	ΔT	19	16	12	-	19	16	12	-	19	16	12	-	19	17	13	-	19	16	12	-	18	15	12	-
	kW	2.09	2.14	2.21	-	2.26	2.31	2.39	-	2.41	2.47	2.56	-	2.55	2.61	2.70	-	2.66	2.73	2.82	-	2.76	2.83	2.93	-
	Amps	8.2	8.4	8.7	-	8.9	9.1	9.4	-	9.7	9.9	10.3	-	10.4	10.7	11.0	-	11.1	11.4	11.8	-	11.8	12.1	12.5	-
	HI PR	220	237	240	-	249	268	271	-	283	304	309	-	322	347	352	-	348	374	380	-	413	444	450	-
	Lo PR	118	122	133	-	122	126	137	-	126	130	142	-	129	134	146	-	132	136	149	-	135	140	152	-
	MBh	35.6	36.9	40.5	-	34.8	36.1	39.5	-	34.0	35.2	38.6	-	33.2	34.4	37.7	-	31.5	32.7	35.8	-	29.2	30.2	33.1	-
	S/T	0.70	0.59	0.41	-	0.73	0.61	0.42	-	0.75	0.62	0.43	-	0.77	0.64	0.45	-	0.80	0.67	0.46	-	0.81	0.67	0.47	-
	ΔT	20	17	13	-	20	17	13	-	20	17	13	-	20	17	13	-	20	17	13	-	18	16	12	-
kW	2.07	2.12	2.19	-	2.24	2.29	2.37	-	2.39	2.45	2.53	-	2.53	2.59	2.68	-	2.64	2.70	2.80	-	2.74	2.80	2.90	-	
Amps	8.1	8.3	8.6	-	8.8	9.0	9.3	-	9.6	9.9	10.2	-	10.3	10.6	10.9	-	11.0	11.3	11.7	-	11.7	12.0	12.4	-	
HI PR	218	234	238	-	246	265	269	-	280	301	306	-	319	343	348	-	345	371	376	-	409	439	446	-	
Lo PR	117	121	132	-	121	125	136	-	125	129	141	-	128	132	144	-	131	135	147	-	134	138	151	-	
MBh	32.9	34.1	37.4	-	32.1	33.3	36.5	-	31.4	32.5	35.6	-	30.6	31.7	34.8	-	29.1	30.1	33.0	-	26.9	27.9	30.6	-	
S/T	0.68	0.57	0.39	-	0.70	0.59	0.41	-	0.72	0.60	0.42	-	0.74	0.62	0.43	-	0.77	0.65	0.45	-	0.78	0.65	0.45	-	
ΔT	20	17	13	-	20	18	13	-	20	18	13	-	20	18	13	-	20	17	13	-	19	16	12	-	
kW	2.05	2.10	2.17	-	2.22	2.27	2.35	-	2.37	2.43	2.51	-	2.50	2.56	2.65	-	2.62	2.68	2.77	-	2.71	2.78	2.88	-	
Amps	8.1	8.3	8.5	-	8.7	9.0	9.3	-	9.5	9.8	10.1	-	10.2	10.5	10.8	-	10.9	11.2	11.5	-	11.6	11.8	12.3	-	
HI PR	216	232	235	-	244	262	266	-	278	298	303	-	316	340	345	-	341	367	372	-	405	435	441	-	
Lo PR	116	120	131	-	120	123	135	-	124	127	139	-	127	131	143	-	129	134	146	-	133	137	149	-	

75	MBh	37.3	38.4	41.6	44.7	36.5	37.5	40.6	43.6	35.6	36.7	39.7	42.6	34.7	35.8	38.7	41.5	33.0	34.0	36.8	39.5	30.6	31.5	34.1	36.6
	S/T	0.84	0.75	0.57	0.37	0.87	0.78	0.59	0.38	0.89	0.80	0.60	0.39	0.92	0.82	0.62	0.40	0.95	0.85	0.65	0.42	0.96	0.86	0.65	0.42
	ΔT	22	20	16	11	22	20	17	11	22	20	17	11	22	20	17	12	22	20	16	11	20	19	15	11
	kW	2.09	2.14	2.21	2.28	2.26	2.31	2.39	2.48	2.41	2.47	2.56	2.65	2.55	2.61	2.70	2.80	2.66	2.73	2.82	2.92	2.76	2.83	2.93	3.03
	Amps	8.2	8.4	8.7	9.0	8.9	9.1	9.4	9.8	9.7	9.9	10.3	10.7	10.4	10.7	11.0	11.5	11.1	11.4	11.8	12.2	11.8	12.1	12.5	13.0
	HI PR	220	237	240	245	249	268	271	277	283	304	309	316	322	347	352	359	348	374	380	388	413	444	450	460
	Lo PR	118	122	133	142	122	126	137	146	126	130	142	151	129	134	146	155	132	136	149	158	135	140	152	162
	MBh	36.3	37.3	40.4	43.4	35.4	36.5	39.5	42.4	34.6	35.6	38.5	41.3	33.7	34.7	37.6	40.3	32.0	33.0	35.7	38.3	29.7	30.6	33.1	35.5
	S/T	0.80	0.72	0.54	0.35	0.83	0.74	0.56	0.36	0.85	0.76	0.58	0.37	0.88	0.78	0.59	0.38	0.91	0.81	0.62	0.40	0.92	0.82	0.62	0.40
	ΔT	23	21	17	12	23	21	17	12	23	21	17	12	23	21	17	12	23	21	17	12	21	20	16	11
kW	2.07	2.12	2.19	2.26	2.24	2.29	2.37	2.45	2.39	2.45	2.53	2.62	2.53	2.59	2.68	2.77	2.64	2.70	2.80	2.90	2.74	2.80	2.90	3.01	
Amps	8.1	8.3	8.6	9.0	8.8	9.0	9.3	9.7	9.6	9.9	10.2	10.6	10.3	10.6	10.9	11.4	11.0	11.3	11.7	12.1	11.7	12.0	12.4	12.9	
HI PR	218	234	238	243	246	265	269	275	280	301	306	312	319	343	348	356	345	371	376	384	409	439	446	455	
Lo PR	117	121	132	141	121	125	136	145	125	129	141	150	128	132	144	154	131	135	147	157	134	138	151	161	
MBh	33.5	34.5	37.3	40.0	32.7	33.6	36.4	39.1	31.9	32.8	35.6	38.2	31.1	32.0	34.7	37.2	29.6	30.4	33.0	35.4	27.4	28.2	30.5	32.8	
S/T	0.77	0.69	0.52	0.34	0.80	0.71	0.54	0.35	0.82	0.73	0.55	0.36	0.85	0.76	0.57	0.37	0.88	0.79	0.59	0.38	0.89	0.79	0.60	0.39	
ΔT	23	21	17	12	23	22	18	12	23	22	18	12	24	22	18	12	24	22	18	12	22	20	16	11	
kW	2.05	2.10	2.17	2.24	2.22	2.27	2.35	2.43	2.37	2.43	2.51	2.60	2.50	2.56	2.65	2.75	2.62	2.68	2.77	2.87	2.71	2.78	2.88	2.98	
Amps	8.1	8.3	8.5	8.9	8.7	9.0	9.3	9.6	9.5	9.8	10.1	10.5	10.2	10.5	10.8	11.2	10.9	11.2	11.5	12.0	11.6	11.8	12.3	12.7	
HI PR	216	232	235	241	244	262	266	272	278	298	303	309	316	340	345	352	341	367	372	380	405	435	441	451	
Lo PR	116	120	131	139	120	123	135	143	124	127	139	148	127	131	143	152	129	134	146	155	133	137	149	159	

IDB = Entering Indoor Dry Bulb Temperature  
 High and low pressures are measured at the liquid and suction service valves.  
 Shaded area is ACCA (TVA) conditions  
 kW = Total system power  
 Amps = outdoor unit amps (comp.+fan)

IDB	AIRFLOW	OUTDOOR AMBIENT TEMPERATURE												ENTERING INDOOR WET BULB TEMPERATURE											
		65°F				75°F				85°F				95°F				105°F				115°F			
		59	63	67	71	59	63	67	71	59	63	67	71	59	63	67	71	59	63	67	71	59	63	67	71
80	MBh	38.0	38.8	41.5	44.4	37.1	37.9	40.5	43.3	36.2	37.0	39.6	42.3	35.4	36.1	38.6	41.3	33.6	34.3	36.7	39.2	31.1	31.8	34.0	36.3
	S/T	0.92	0.86	0.70	0.52	0.95	0.89	0.73	0.54	1.00	0.92	0.75	0.56	1.00	0.95	0.77	0.58	1.00	1.00	0.80	0.60	1.00	1.00	0.81	0.60
	ΔT	24	23	20	16	24	23	20	16	25	23	20	16	24	24	21	16	23	24	20	16	22	22	19	15
	kW	2.09	2.14	2.21	2.28	2.26	2.31	2.39	2.48	2.41	2.47	2.56	2.65	2.55	2.61	2.70	2.80	2.66	2.73	2.82	2.92	2.76	2.83	2.93	3.03
	Amps	8.2	8.4	8.7	9.0	8.9	9.1	9.4	9.8	9.7	9.9	10.3	10.7	10.4	10.7	11.0	11.5	11.1	11.4	11.8	12.2	11.8	12.1	12.5	13.0
	HI PR	220	237	240	245	249	268	271	277	283	304	309	316	322	347	352	359	348	374	380	388	413	444	450	460
	Lo PR	118	122	133	142	122	126	137	146	126	130	142	151	129	134	146	155	132	136	149	158	135	140	152	162
	MBh	36.9	37.7	40.3	43.1	36.0	36.8	39.3	42.1	35.2	35.9	38.4	41.1	34.3	35.1	37.5	40.1	32.6	33.3	35.6	38.1	30.2	30.9	33.0	35.2
	S/T	0.88	0.82	0.67	0.50	0.91	0.85	0.69	0.52	0.93	0.87	0.71	0.53	0.96	0.90	0.73	0.55	1.00	0.94	0.76	0.57	1.00	0.94	0.77	0.57
	ΔT	25	24	21	17	26	25	21	17	26	25	21	17	26	25	22	17	25	24	21	17	24	23	20	16
kW	2.07	2.12	2.19	2.26	2.24	2.29	2.37	2.45	2.39	2.45	2.53	2.62	2.53	2.59	2.68	2.77	2.64	2.70	2.80	2.90	2.74	2.80	2.90	3.01	
Amps	8.1	8.3	8.6	9.0	8.8	9.0	9.3	9.7	9.6	9.9	10.2	10.6	10.3	10.6	10.9	11.4	11.0	11.3	11.7	12.1	11.7	12.0	12.4	12.9	
HI PR	218	234	238	243	246	265	269	275	280	301	306	312	319	343	348	356	345	371	376	384	409	439	446	455	
Lo PR	117	121	132	141	121	125	136	145	125	129	141	150	128	132	144	154	131	135	147	157	134	138	151	161	
MBh	34.1	34.8	37.2	39.7	33.3	34.0	36.3	38.8	32.5	33.2	35.4	37.9	31.7	32.4	34.6	37.0	30.1	30.8	32.9	35.1	27.9	28.5	30.4	32.5	
S/T	0.85	0.79	0.65	0.48	0.88	0.82	0.67	0.50	0.90	0.84	0.69	0.51	0.93	0.87	0.71	0.53	0.96	0.90	0.74	0.55	0.97	0.91	0.74	0.55	
ΔT	26	25	22	17	26	25	22	17	26	25	22	17	26	25	22	18	26	25	22	17	24	23	20	16	
kW	2.05	2.10	2.17	2.24	2.22	2.27	2.35	2.43	2.37	2.43	2.51	2.60	2.50	2.56	2.65	2.75	2.62	2.68	2.77	2.87	2.71	2.78	2.88	2.98	
Amps	8.1	8.3	8.5	8.9	8.7	9.0	9.3	9.6	9.5	9.8	10.1	10.5	10.2	10.5	10.8	11.2	10.9	11.2	11.5	12.0	11.6	11.8	12.3	12.7	
HI PR	216	232	235	241	244	262	266	272	278	298	303	309	316	340	345	352	341	367	372	380	405	435	441	451	
Lo PR	116	120	131	139	120	123	135	143	124	127	139	148	127	131	143	152	129	134	146	155	133	137	149	159	

85	MBh	38.7	39.4	41.3	44.0	37.8	38.5	40.3	43.0	36.9	37.6	39.4	42.0	36.0	36.7	38.4	41.0	34.2	34.8	36.5	38.9	31.7	32.3	33.8	36.1
	S/T	0.96	0.93	0.84	0.68	1.00	0.96	0.87	0.71	1.00	0.99	0.89	0.72	1.00	1.00	0.92	0.75	1.00	1.00	0.96	0.78	1.00	1.00	0.96	0.78
	ΔT	26	25	24	21	26	26	24	21	25	26	24	21	25	25	24	21	24	24	24	21	22	22	23	19
	kW	2.09	2.14	2.21	2.28	2.26	2.31	2.39	2.48	2.41	2.47	2.56	2.65	2.55	2.61	2.70	2.80	2.66	2.73	2.82	2.92	2.76	2.83	2.93	3.03
	Amps	8.2	8.4	8.7	9.0	8.9	9.1	9.4	9.8	9.7	9.9	10.3	10.7	10.4	10.7	11.0	11.5	11.1	11.4	11.8	12.2	11.8	12.1	12.5	13.0
	HI PR	220	237	240	245	249	268	271	277	283	304	309	316	322	347	352	359	348	374	380	388	413	444	450	460
	Lo PR	118	122	133	142	122	126	137	146	126	130	142	151	129	134	146	155	132	136	149	158	135	140	152	162
	MBh	37.5	38.3	40.1	42.8	36.7	37.4	39.1	41.8	35.8	36.5	38.2	40.8	34.9	35.6	37.3	39.8	33.2	33.8	35.4	37.8	30.7	31.3	32.8	35.0
	S/T	0.92	0.89	0.80	0.65	0.95	0.92	0.83	0.67	0.98	0.94	0.85	0.69	1.00	0.97	0.88	0.71	1.00	1.00	0.91	0.74	1.00	1.00	0.92	0.75
	ΔT	27	27	25	22	27	27	25	22	27	27	25	22	27	27	26	22	26	26	25	22	24	25	24	20
kW	2.07	2.12	2.19	2.26	2.24	2.29	2.37	2.45	2.39	2.45	2.53	2.62	2.53	2.59	2.68	2.77	2.64	2.70	2.80	2.90	2.74	2.80	2.90	3.01	
Amps	8.1	8.3	8.6	9.0	8.8	9.0	9.3	9.7	9.6	9.9	10.2	10.6	10.3	10.6	10.9	11.4	11.0	11.3	11.7	12.1	11.7	12.0	12.4	12.9	
HI PR	218	234	238	243	246	265	269	275	280	301	306	312	319	343	348	356	345	371	376	384	409	439	446	455	
Lo PR	117	121	132	141	121	125	136	145	125	129	141	150	128	132	144	154	131	135	147	157	134	138	151	161	
MBh	34.6	35.3	37.0	39.5	33.8	34.5	36.1	38.5	33.0	33.7	35.3	37.6	32.2	32.9	34.4	36.7	30.6	31.2	32.7	34.9	28.4	28.9	30.3	32.3	
S/T	0.89	0.86	0.77	0.63	0.92	0.89	0.80	0.65	0.94	0.91	0.82	0.67	0.97	0.94	0.85	0.69	1.00	0.97	0.88	0.71	1.00	0.98	0.89	0.72	
ΔT	28	27	26	22	28	27	26	22	28	27	26	22	28	28	26	23	27	27	26	22	25	25	24	21	
kW	2.05	2.10	2.17	2.24	2.22	2.27	2.35	2.43	2.37	2.43	2.51	2.60	2.50	2.56	2.65	2.75	2.62	2.68	2.77	2.87	2.71	2.78	2.88	2.98	
Amps	8.1	8.3	8.5	8.9	8.7	9.0	9.3	9.6	9.5	9.8	10.1	10.5	10.2	10.5	10.8	11.2	10.9	11.2	11.5	12.0	11.6	11.8	12.3	12.7	
HI PR	216	232	235	241	244	262	266	272	278	298	303	309	316	340	345	352	341	367	372	380	405	435	441	451	
Lo PR	116	120	131	139	120	123	135	143	124	127	139	148	127	131	143	152	129	134	146	155	133	137	149	159	

IDB = Entering Indoor Dry Bulb Temperature  
 High and low pressures are measured at the liquid and suction service valves.  
 Shaded area is AHRI (TVA) conditions  
 kW = Total system power  
 Amps = outdoor unit amps (comp.+fan)

IDB		OUTDOOR AMBIENT TEMPERATURE												ENTERING INDOOR WET BULB TEMPERATURE																							
		65°F						75°F						85°F						95°F						105°F						115°F					
		59	63	67	71	59	63	67	71	59	63	67	71	59	63	67	71	59	63	67	71	59	63	67	71	59	63	67	71	59	63	67	71				
70	MBh	34.6	35.8	39.3	-	33.8	35.0	38.3	-	33.0	34.2	37.4	-	32.2	33.3	36.5	-	30.5	31.7	34.7	-	28.3	29.3	32.1	-	30.5	31.7	34.7	-	28.3	29.3	32.1	-				
	S/T	0.76	0.64	0.44	-	0.79	0.66	0.46	-	0.81	0.68	0.47	-	0.83	0.70	0.48	-	0.87	0.72	0.50	-	0.87	0.73	0.51	-	0.87	0.72	0.50	-	0.87	0.73	0.51	-				
	ΔT	18	16	12	-	18	16	12	-	18	16	12	-	19	16	12	-	18	16	12	-	17	15	11	-	18	16	12	-	17	15	11	-				
	kW	1.87	1.91	1.97	-	2.02	2.07	2.14	-	2.16	2.21	2.29	-	2.28	2.34	2.42	-	2.39	2.44	2.53	-	2.47	2.53	2.62	-	2.39	2.44	2.53	-	2.47	2.53	2.62	-				
	Amps	7.2	7.4	7.6	-	7.8	8.0	8.3	-	8.5	8.7	9.0	-	9.1	9.4	9.7	-	9.7	10.0	10.3	-	10.4	10.6	11.0	-	9.7	10.0	10.3	-	10.4	10.6	11.0	-				
	HI PR	216	232	235	-	244	262	266	-	277	298	303	-	316	340	345	-	356	382	388	-	398	428	434	-	356	382	388	-	398	428	434	-				
	Lo PR	121	125	137	-	125	129	141	-	129	133	146	-	133	137	149	-	135	140	152	-	139	143	156	-	135	140	152	-	139	143	156	-				
	MBh	33.6	34.8	38.1	-	32.8	34.0	37.2	-	32.0	33.2	36.3	-	31.2	32.4	35.5	-	29.7	30.7	33.7	-	27.5	28.5	31.2	-	29.7	30.7	33.7	-	27.5	28.5	31.2	-				
	S/T	0.73	0.61	0.42	-	0.75	0.63	0.44	-	0.77	0.64	0.45	-	0.80	0.66	0.46	-	0.83	0.69	0.48	-	0.83	0.70	0.48	-	0.83	0.69	0.48	-	0.83	0.70	0.48	-				
	ΔT	19	16	13	-	19	17	13	-	19	17	13	-	19	17	13	-	19	17	13	-	18	16	12	-	19	17	13	-	18	16	12	-				
kW	1.85	1.89	1.96	-	2.00	2.05	2.12	-	2.14	2.19	2.27	-	2.26	2.32	2.40	-	2.36	2.42	2.51	-	2.45	2.51	2.60	-	2.36	2.42	2.51	-	2.45	2.51	2.60	-					
Amps	7.1	7.3	7.6	-	7.7	7.9	8.2	-	8.4	8.7	9.0	-	9.0	9.3	9.6	-	9.7	9.9	10.2	-	10.3	10.5	10.9	-	9.7	9.9	10.2	-	10.3	10.5	10.9	-					
HI PR	214	230	233	-	242	260	263	-	275	295	300	-	313	336	341	-	352	378	384	-	394	424	430	-	352	378	384	-	394	424	430	-					
Lo PR	120	124	135	-	124	128	139	-	128	132	144	-	131	136	148	-	134	138	151	-	137	142	155	-	134	138	151	-	137	142	155	-					
MBh	31.0	32.1	35.2	-	30.3	31.4	34.4	-	29.5	30.6	33.5	-	28.8	29.9	32.7	-	27.4	28.4	31.1	-	25.4	26.3	28.8	-	27.4	28.4	31.1	-	25.4	26.3	28.8	-					
S/T	0.70	0.58	0.40	-	0.73	0.61	0.42	-	0.74	0.62	0.43	-	0.77	0.64	0.44	-	0.80	0.67	0.46	-	0.80	0.67	0.46	-	0.80	0.67	0.46	-	0.80	0.67	0.46	-					
ΔT	19	17	13	-	20	17	13	-	20	17	13	-	20	17	13	-	20	17	13	-	18	16	12	-	20	17	13	-	18	16	12	-					
kW	1.83	1.88	1.94	-	1.99	2.03	2.10	-	2.12	2.17	2.25	-	2.24	2.29	2.38	-	2.34	2.40	2.48	-	2.43	2.49	2.58	-	2.34	2.40	2.48	-	2.43	2.49	2.58	-					
Amps	7.1	7.2	7.5	-	7.7	7.9	8.1	-	8.4	8.6	8.9	-	9.0	9.2	9.5	-	9.6	9.8	10.1	-	10.2	10.4	10.8	-	9.6	9.8	10.1	-	10.2	10.4	10.8	-					
HI PR	212	227	231	-	239	257	261	-	272	292	297	-	310	333	338	-	348	375	380	-	390	420	426	-	348	375	380	-	390	420	426	-					
Lo PR	119	123	134	-	123	126	138	-	127	131	143	-	130	134	147	-	133	137	149	-	136	140	153	-	133	137	149	-	136	140	153	-					

75	MBh	35.2	36.2	39.2	42.0	34.3	35.4	38.3	41.1	33.5	34.5	37.4	40.1	32.7	33.7	36.4	39.1	31.1	32.0	34.6	37.2	28.8	29.6	32.1	34.4	31.1	32.0	34.6	37.2	28.8	29.6	32.1	34.4	
	S/T	0.86	0.77	0.59	0.38	0.90	0.80	0.61	0.39	0.92	0.82	0.62	0.40	0.95	0.85	0.64	0.41	0.94	0.88	0.67	0.43	0.99	0.89	0.67	0.43	0.94	0.88	0.67	0.43	0.99	0.89	0.67	0.43	
	ΔT	21	19	16	11	21	20	16	11	22	21	17	12	22	21	17	12	22	21	16	11	20	18	15	10	21	20	16	11	20	18	15	10	
	kW	1.87	1.91	1.97	2.04	2.02	2.07	2.14	2.22	2.16	2.21	2.29	2.37	2.28	2.34	2.42	2.51	2.39	2.44	2.53	2.62	2.47	2.53	2.62	2.72	2.39	2.44	2.53	2.62	2.47	2.53	2.62	2.72	
	Amps	7.2	7.4	7.6	7.9	7.8	8.0	8.3	8.6	8.5	8.7	9.0	9.4	9.1	9.4	9.7	10.1	9.7	10.0	10.3	10.8	10.4	10.6	11.0	11.4	9.7	10.0	10.3	10.8	10.4	10.6	11.0	11.4	
	HI PR	216	232	235	241	244	262	266	272	277	298	303	309	316	340	345	352	356	356	382	388	396	398	428	434	444	356	382	388	396	398	428	434	444
	Lo PR	121	125	137	146	125	129	141	150	129	133	146	155	133	137	149	159	135	140	152	162	139	143	156	166	135	140	152	162	139	143	156	166	
	MBh	34.1	35.1	38.0	40.8	33.3	34.3	37.2	39.9	32.5	33.5	36.3	38.9	31.7	32.7	35.4	38.0	30.2	31.1	33.6	36.1	27.9	28.8	31.1	33.4	30.2	31.1	33.6	36.1	27.9	28.8	31.1	33.4	
	S/T	0.82	0.74	0.56	0.36	0.85	0.76	0.58	0.37	0.88	0.78	0.59	0.38	0.90	0.81	0.61	0.39	0.94	0.84	0.64	0.41	0.95	0.85	0.64	0.41	0.94	0.84	0.64	0.41	0.95	0.85	0.64	0.41	
	ΔT	22	20	17	11	22	21	17	12	22	21	17	12	22	21	17	12	22	21	16	11	22	21	19	16	11	22	21	17	12	21	19	16	11
kW	1.85	1.89	1.96	2.03	2.00	2.05	2.12	2.20	2.14	2.19	2.27	2.35	2.26	2.32	2.40	2.48	2.36	2.42	2.51	2.60	2.45	2.51	2.60	2.69	2.36	2.42	2.51	2.60	2.45	2.51	2.60	2.69		
Amps	7.1	7.3	7.6	7.9	7.7	7.9	8.2	8.5	8.4	8.7	9.0	9.3	9.0	9.3	9.6	10.0	9.7	9.9	10.2	10.6	10.3	10.5	10.9	11.3	9.7	9.9	10.2	10.6	10.3	10.5	10.9	11.3		
HI PR	214	230	233	238	242	260	263	269	275	295	300	306	313	336	341	349	352	352	378	384	392	394	424	430	439	352	378	384	392	394	424	430	439	
Lo PR	120	124	135	144	124	128	139	148	128	132	144	154	131	136	148	158	134	138	151	161	137	142	155	165	134	138	151	161	137	142	155	165		
MBh	31.5	32.4	35.1	37.7	30.8	31.7	34.3	36.8	30.0	30.9	33.5	35.9	29.3	30.2	32.7	35.1	27.8	28.7	31.0	33.3	25.8	26.6	28.7	30.8	27.8	28.7	31.0	33.3	25.8	26.6	28.7	30.8		
S/T	0.80	0.71	0.54	0.35	0.82	0.74	0.56	0.36	0.85	0.76	0.57	0.37	0.87	0.78	0.59	0.38	0.91	0.81	0.61	0.39	0.91	0.82	0.62	0.40	0.91	0.81	0.61	0.39	0.91	0.82	0.62	0.40		
ΔT	22	21	17	12	23	21	17	12	23	21	17	12	23	21	17	12	23	21	16	11	23	21	19	16	11	23	21	17	12	21	19	16	11	
kW	1.83	1.88	1.94	2.01	1.99	2.03	2.10	2.18	2.12	2.17	2.25	2.33	2.24	2.29	2.38	2.46	2.34	2.40	2.48	2.57	2.43	2.49	2.58	2.67	2.34	2.40	2.48	2.57	2.43	2.49	2.58	2.67		
Amps	7.1	7.2	7.5	7.8	7.7	7.9	8.1	8.4	8.4	8.6	8.9	9.2	9.0	9.2	9.5	9.9	9.6	9.8	10.1	10.5	10.2	10.4	10.8	11.2	9.6	9.8	10.1	10.5	10.2	10.4	10.8	11.2		
HI PR	212	227	231	236	239	257	261	267	272	292	297	303	310	333	338	345	348	375	380	388	390	420	426	435	348	375	380	388	390	420	426	435		
Lo PR	119	123	134	143	123	126	138	147	127	131	143	152	130	134	147	156	133	137	149	159	136	140	153	163	133	137	149	159	136	140	153	163		

kW = Total system power  
Amps = outdoor unit amps (comp.+fan)

Shaded area is ACCA (TVA) conditions

IDB = Entering Indoor Dry Bulb Temperature  
High and low pressures are measured at the liquid and suction service valves.



IDB	AIRFLOW	OUTDOOR AMBIENT TEMPERATURE												ENTERING INDOOR WET BULB TEMPERATURE											
		65°F				75°F				85°F				95°F				105°F				115°F			
		59	63	67	71	59	63	67	71	59	63	67	71	59	63	67	71	59	63	67	71	59	63	67	71
80	MBh	35.8	36.6	39.1	41.8	34.9	35.7	38.2	40.8	34.1	34.9	37.2	39.8	33.3	34.0	36.3	38.8	31.6	32.3	34.5	36.9	29.3	29.9	32.0	34.2
	S/T	0.95	0.89	0.72	0.54	1.00	0.92	0.75	0.56	1.00	0.95	0.77	0.58	1.00	1.00	0.79	0.59	1.00	1.00	0.82	0.62	1.00	1.00	0.83	0.62
	ΔT	24	23	20	16	24	23	20	16	24	23	20	16	23	24	20	16	22	22	20	16	20	21	18	15
	kW	1.87	1.91	1.97	2.04	2.02	2.07	2.14	2.20	2.16	2.21	2.29	2.37	2.28	2.34	2.42	2.51	2.39	2.44	2.53	2.62	2.47	2.53	2.62	2.72
	Amps	7.2	7.4	7.6	7.9	7.8	8.0	8.3	8.6	8.5	8.7	9.0	9.4	9.1	9.4	9.7	10.1	9.7	10.0	10.3	10.8	10.4	10.6	11.0	11.4
	HI PR	216	232	235	241	244	262	266	272	277	298	303	309	316	340	345	352	356	382	388	396	398	428	434	444
	Lo PR	121	125	137	146	125	129	141	150	129	133	146	155	133	137	149	159	135	140	152	162	139	143	156	166
	MBh	34.7	35.5	37.9	40.5	33.9	34.7	37.0	39.6	33.1	33.8	36.2	38.7	32.3	33.0	35.3	37.7	30.7	31.4	33.5	35.8	28.4	29.1	31.0	33.2
	S/T	0.90	0.85	0.69	0.52	0.94	0.88	0.72	0.53	0.96	0.90	0.73	0.55	0.99	0.93	0.76	0.57	1.00	0.97	0.79	0.59	1.00	0.97	0.79	0.59
	ΔT	25	24	20	16	25	24	21	17	25	24	21	17	25	24	21	17	24	24	21	16	22	22	19	15
kW	1.85	1.89	1.96	2.03	2.00	2.05	2.12	2.20	2.14	2.19	2.27	2.35	2.26	2.32	2.40	2.48	2.36	2.42	2.51	2.60	2.45	2.51	2.60	2.69	
Amps	7.1	7.3	7.6	7.9	7.7	7.9	8.2	8.5	8.4	8.7	9.0	9.3	9.0	9.3	9.6	10.0	9.7	9.9	10.2	10.6	10.3	10.5	10.9	11.3	
HI PR	214	230	233	238	242	260	263	269	275	295	300	306	313	336	341	349	352	378	384	392	394	424	430	439	
Lo PR	120	124	135	144	124	128	139	148	128	132	144	154	131	136	148	158	134	138	151	161	137	142	155	165	
MBh	32.1	32.8	35.0	37.4	31.3	32.0	34.2	36.5	30.6	31.2	33.4	35.7	29.8	30.5	32.6	34.8	28.3	29.0	30.9	33.1	26.2	26.8	28.7	30.6	
S/T	0.87	0.82	0.67	0.50	0.90	0.85	0.69	0.52	0.93	0.87	0.71	0.53	0.96	0.90	0.73	0.55	0.99	0.93	0.76	0.57	1.00	0.94	0.76	0.57	
ΔT	25	24	21	17	25	24	21	17	25	24	21	17	26	25	21	17	25	24	21	17	24	23	20	16	
kW	1.83	1.88	1.94	2.01	1.99	2.03	2.10	2.18	2.12	2.17	2.25	2.33	2.24	2.29	2.38	2.46	2.34	2.40	2.48	2.57	2.43	2.49	2.58	2.67	
Amps	7.1	7.2	7.5	7.8	7.7	7.9	8.1	8.4	8.4	8.6	8.9	9.2	9.0	9.2	9.5	9.9	9.6	9.8	10.1	10.5	10.2	10.4	10.8	11.2	
HI PR	212	227	231	236	239	257	261	267	272	292	297	303	310	333	338	345	348	375	380	388	390	420	426	435	
Lo PR	119	123	134	143	123	126	138	147	127	131	143	152	130	134	147	156	133	137	149	159	136	140	153	163	

85	MBh	36.4	37.1	38.9	41.5	35.6	36.2	38.0	40.5	34.7	35.4	37.1	39.5	33.9	34.5	36.2	38.6	32.2	32.8	34.3	36.6	29.8	30.4	31.8	33.9
	S/T	0.99	0.96	0.87	0.70	1.00	0.99	0.90	0.73	1.00	1.00	0.92	0.75	1.00	1.00	0.95	0.77	1.00	1.00	0.99	0.80	1.00	1.00	0.99	0.81
	ΔT	25	25	23	20	25	25	24	20	24	25	24	20	23	24	24	21	22	23	23	20	21	21	22	19
	kW	1.87	1.91	1.97	2.04	2.02	2.07	2.14	2.22	2.16	2.21	2.29	2.37	2.28	2.34	2.42	2.51	2.39	2.44	2.53	2.62	2.47	2.53	2.62	2.72
	Amps	7.2	7.4	7.6	7.9	7.8	8.0	8.3	8.6	8.5	8.7	9.0	9.4	9.1	9.4	9.7	10.1	9.7	10.0	10.3	10.8	10.4	10.6	11.0	11.4
	HI PR	216	232	235	241	244	262	266	272	277	298	303	309	316	340	345	352	356	382	388	396	398	428	434	444
	Lo PR	121	125	137	146	125	129	141	150	129	133	146	155	133	137	149	159	135	140	152	162	139	143	156	166
	MBh	35.3	36.0	37.7	40.3	34.5	35.2	36.9	39.3	33.7	34.4	36.0	38.4	32.9	33.5	35.1	37.4	31.2	31.8	33.3	35.6	28.9	29.5	30.9	33.0
	S/T	0.95	0.92	0.83	0.67	0.98	0.95	0.86	0.69	1.00	0.97	0.88	0.71	1.00	1.00	0.91	0.74	1.00	1.00	0.94	0.76	1.00	1.00	0.95	0.77
	ΔT	26	26	24	21	27	26	25	21	26	26	25	21	26	26	25	22	24	25	25	21	23	23	23	20
kW	1.85	1.89	1.96	2.03	2.00	2.05	2.12	2.20	2.14	2.19	2.27	2.35	2.26	2.32	2.40	2.48	2.36	2.42	2.51	2.60	2.45	2.51	2.60	2.69	
Amps	7.1	7.3	7.6	7.9	7.7	7.9	8.2	8.5	8.4	8.7	9.0	9.3	9.0	9.3	9.6	10.0	9.7	9.9	10.2	10.6	10.3	10.5	10.9	11.3	
HI PR	214	230	233	238	242	260	263	269	275	295	300	306	313	336	341	349	352	378	384	392	394	424	430	439	
Lo PR	120	124	135	144	124	128	139	148	128	132	144	154	131	136	148	158	134	138	151	161	137	142	155	165	
MBh	32.6	33.3	34.8	37.2	31.9	32.5	34.0	36.3	31.1	31.7	33.2	35.4	30.3	30.9	32.4	34.6	28.8	29.4	30.8	32.8	26.7	27.2	28.5	30.4	
S/T	0.91	0.88	0.80	0.65	0.95	0.91	0.83	0.67	0.97	0.94	0.85	0.69	1.00	0.97	0.87	0.71	1.00	1.00	0.91	0.74	1.00	1.00	0.91	0.74	
ΔT	26.8	26	25	22	27	27	25	22	27	27	25	22	27	27	25	22	26	26	25	22	24	24	23	20	
kW	1.83	1.88	1.94	2.01	1.99	2.03	2.10	2.18	2.12	2.17	2.25	2.33	2.24	2.29	2.38	2.46	2.34	2.40	2.48	2.57	2.43	2.49	2.58	2.67	
Amps	7.1	7.2	7.5	7.8	7.7	7.9	8.1	8.4	8.4	8.6	8.9	9.2	9.0	9.2	9.5	9.9	9.6	9.8	10.1	10.5	10.2	10.4	10.8	11.2	
HI PR	212	227	231	236	239	257	261	267	272	292	297	303	310	333	338	345	348	375	380	388	390	420	426	435	
Lo PR	119	123	134	143	123	126	138	147	127	131	143	152	130	134	147	156	133	137	149	159	136	140	153	163	

IDB = Entering Indoor Dry Bulb Temperature  
 High and low pressures are measured at the liquid and suction service valves.  
 Shaded area is AHRI (TVA) conditions  
 kW = Total system power  
 Amps = outdoor unit amps (comp.+fan)

IDB	AIRFLOW	OUTDOOR AMBIENT TEMPERATURE												ENTERING INDOOR WET BULB TEMPERATURE											
		65°F				75°F				85°F				95°F				105°F				115°F			
		59	63	67	71	59	63	67	71	59	63	67	71	59	63	67	71	59	63	67	71	59	63	67	71
70	MBh	48.2	50.0	54.8	-	47.1	48.8	53.5	-	46.0	47.7	52.2	-	44.9	46.5	50.9	-	42.6	44.2	48.4	-	39.5	40.9	44.8	-
	S/T	0.77	0.64	0.44	-	0.79	0.66	0.46	-	0.81	0.68	0.47	-	0.84	0.70	0.49	-	0.87	0.73	0.50	-	0.88	0.73	0.51	-
	ΔT	17	15	11	-	17	15	11	-	17	15	11	-	18	15	12	-	18	15	11	-	16	14	11	-
	kW	2.87	2.94	3.03	-	3.10	3.17	3.27	-	3.20	3.37	3.48	-	3.47	3.55	3.67	-	3.62	3.70	3.83	-	3.75	3.84	3.97	-
	Amps	10.2	10.5	10.8	-	11.1	11.4	11.7	-	12.1	12.4	12.8	-	13.0	13.3	13.7	-	13.8	14.2	14.7	-	14.7	15.1	15.6	-
	HI PR	228	245	248	-	257	277	280	-	292	315	319	-	333	358	363	-	375	403	409	-	420	451	458	-
	Lo PR	121	124	136	-	124	128	140	-	128	132	145	-	132	136	148	-	134	139	151	-	138	142	155	-
	MBh	46.8	48.5	53.2	-	45.7	47.4	51.9	-	44.6	46.3	50.7	-	43.5	45.1	49.5	-	41.4	42.9	47.0	-	38.3	39.7	43.5	-
	S/T	0.73	0.61	0.42	-	0.76	0.63	0.44	-	0.78	0.65	0.45	-	0.80	0.67	0.46	-	0.83	0.69	0.48	-	0.84	0.70	0.48	-
	ΔT	18	16	12	-	18	16	12	-	18	16	12	-	18	16	12	-	18	16	12	-	17	15	11	-
kW	2.85	2.91	3.01	-	3.07	3.14	3.24	-	3.27	3.34	3.45	-	3.44	3.52	3.64	-	3.59	3.67	3.80	-	3.72	3.80	3.93	-	
Amps	10.1	10.4	10.7	-	11.0	11.2	11.6	-	12.0	12.3	12.7	-	12.8	13.2	13.6	-	13.7	14.0	14.5	-	14.5	14.9	15.4	-	
HI PR	225	242	246	-	255	274	278	-	290	311	316	-	330	355	360	-	371	399	405	-	416	447	453	-	
Lo PR	119	123	134	-	123	127	138	-	127	131	143	-	130	135	147	-	133	137	150	-	136	141	154	-	
MBh	43.2	44.8	49.1	-	42.2	43.7	47.9	-	41.2	42.7	46.8	-	40.2	41.7	45.6	-	38.2	39.6	43.4	-	35.4	36.7	40.2	-	
S/T	0.70	0.59	0.41	-	0.73	0.61	0.42	-	0.75	0.62	0.43	-	0.77	0.64	0.45	-	0.80	0.67	0.46	-	0.81	0.67	0.47	-	
ΔT	18	16	12	-	19	16	12	-	19	16	12	-	19	16	12	-	18	16	12	-	17	15	11	-	
kW	2.83	2.89	2.98	-	3.05	3.12	3.22	-	3.24	3.32	3.43	-	3.42	3.49	3.61	-	3.56	3.64	3.76	-	3.69	3.77	3.90	-	
Amps	10.0	10.3	10.6	-	10.9	11.1	11.5	-	11.9	12.2	12.6	-	12.7	13.0	13.5	-	13.6	13.9	14.4	-	14.4	14.8	15.3	-	
HI PR	223	240	243	-	252	271	275	-	287	308	313	-	327	351	356	-	367	395	401	-	411	442	449	-	
Lo PR	118	122	133	-	122	125	137	-	126	130	142	-	129	133	145	-	132	136	148	-	135	139	152	-	

75	MBh	49.0	50.5	54.6	58.7	47.9	49.3	53.4	57.3	46.8	48.1	52.1	55.9	45.6	47.0	50.8	54.6	43.3	44.6	48.3	51.8	40.1	41.3	44.7	48.0
	S/T	0.87	0.78	0.59	0.38	0.90	0.81	0.61	0.39	0.92	0.83	0.63	0.40	0.95	0.85	0.65	0.42	0.99	0.89	0.67	0.43	1.00	0.89	0.68	0.44
	ΔT	20	18	15	10	20	19	15	10	20	19	15	11	20	19	15	11	20	18	15	10	19	17	14	10
	kW	2.87	2.94	3.03	3.13	3.10	3.17	3.27	3.38	3.30	3.37	3.48	3.60	3.47	3.55	3.67	3.80	3.62	3.70	3.83	3.96	3.75	3.84	3.97	4.10
	Amps	10.2	10.5	10.8	11.2	11.1	11.4	11.7	12.2	12.1	12.4	12.8	13.3	13.0	13.3	13.7	14.3	13.8	14.2	14.7	15.3	14.7	15.1	15.6	16.2
	HI PR	228	245	248	254	257	277	280	287	292	315	319	326	333	358	363	371	375	403	409	418	420	451	458	468
	Lo PR	121	124	136	145	124	128	140	149	128	132	145	154	132	136	148	158	134	139	151	161	138	142	155	165
	MBh	47.6	49.0	53.1	56.9	46.5	47.9	51.8	55.6	45.4	46.7	50.6	54.3	44.3	45.6	49.4	53.0	42.1	43.3	46.9	50.3	39.0	40.1	43.4	46.6
	S/T	0.83	0.74	0.56	0.36	0.86	0.77	0.58	0.37	0.88	0.79	0.60	0.38	0.91	0.81	0.62	0.40	0.94	0.84	0.64	0.41	0.95	0.85	0.64	0.41
	ΔT	21	19	16	11	21	19	16	11	21	19	16	11	21	20	16	11	21	19	16	11	20	18	15	10
kW	2.85	2.91	3.01	3.10	3.07	3.14	3.24	3.35	3.27	3.34	3.45	3.57	3.44	3.52	3.64	3.76	3.59	3.67	3.80	3.93	3.72	3.80	3.93	4.07	
Amps	10.1	10.4	10.7	11.1	11.0	11.2	11.6	12.1	12.0	12.3	12.7	13.2	12.8	13.2	13.6	14.2	13.7	14.0	14.5	15.1	14.5	14.9	15.4	16.0	
HI PR	225	242	246	251	255	274	278	284	290	311	316	323	330	355	360	368	371	399	405	414	416	447	453	463	
Lo PR	119	123	134	143	123	127	138	147	127	131	143	152	130	135	147	156	133	137	150	160	136	141	154	163	
MBh	43.9	45.2	49.0	52.6	42.9	44.2	47.8	51.3	41.9	43.1	46.7	50.1	40.9	42.1	45.6	48.9	38.8	40.0	43.3	46.4	36.0	37.0	40.1	43.0	
S/T	0.80	0.72	0.54	0.35	0.83	0.74	0.56	0.36	0.85	0.76	0.58	0.37	0.88	0.79	0.59	0.38	0.91	0.81	0.62	0.40	0.92	0.82	0.62	0.40	
ΔT	21	19	16	11	21	20	16	11	21	20	16	11	22	20	16	11	22	20	16	11	20	18	15	10	
kW	2.83	2.89	2.98	3.08	3.05	3.12	3.22	3.32	3.24	3.32	3.43	3.54	3.42	3.49	3.61	3.73	3.56	3.64	3.76	3.89	3.69	3.77	3.90	4.03	
Amps	10.0	10.3	10.6	11.0	10.9	11.1	11.5	12.0	11.9	12.2	12.6	13.1	12.7	13.0	13.5	14.0	13.6	13.9	14.4	15.0	14.4	14.8	15.3	15.9	
HI PR	223	240	243	249	252	271	275	281	287	308	313	320	327	351	356	364	367	395	401	409	411	442	449	459	
Lo PR	118	122	133	142	122	125	137	146	126	130	142	151	129	133	145	155	132	136	148	158	135	139	152	162	

IDB = Entering Indoor Dry Bulb Temperature  
 High and low pressures are measured at the liquid and suction service valves.  
 Shaded area is ACCA (TVA) conditions  
 kW = Total system power  
 Amps = outdoor unit amps (comp.+fan)

IDB	AIRFLOW	OUTDOOR AMBIENT TEMPERATURE												ENTERING INDOOR WET BULB TEMPERATURE											
		65°F				75°F				85°F				95°F				105°F				115°F			
		59	63	67	71	59	63	67	71	59	63	67	71	59	63	67	71	59	63	67	71	59	63	67	71
80	MBh	49.9	51.0	54.5	58.2	48.7	49.8	53.2	56.9	47.6	48.6	52.0	55.5	46.4	47.4	50.7	54.2	44.1	45.1	48.1	51.5	40.9	41.7	44.6	47.7
	S/T	0.95	0.89	0.73	0.54	1.00	0.93	0.75	0.56	1.00	0.95	0.77	0.58	1.00	1.00	0.80	0.60	1.00	1.00	0.83	0.62	1.00	1.00	0.84	0.63
	ΔT	22	21	19	15	23	22	19	15	22	22	19	15	22	22	19	15	21	21	19	15	19	19	17	14
	kW	2.87	2.94	3.03	3.13	3.10	3.17	3.27	3.38	3.30	3.37	3.48	3.60	3.47	3.55	3.67	3.80	3.62	3.70	3.83	3.96	3.75	3.84	3.97	4.10
	Amps	10.2	10.5	10.8	11.2	11.1	11.4	11.7	12.2	12.1	12.4	12.8	13.3	13.0	13.3	13.7	14.3	13.8	14.2	14.7	15.3	14.7	15.1	15.6	16.2
	HI PR	228	245	248	254	257	277	280	287	292	315	319	326	333	358	363	371	375	403	409	418	420	451	458	468
	Lo PR	121	124	136	145	124	128	140	149	128	132	145	154	132	136	148	158	134	139	151	161	138	142	155	165
	MBh	48.5	49.5	52.9	56.5	47.3	48.4	51.7	55.2	46.2	47.2	50.4	53.9	45.1	46.1	49.2	52.6	42.8	43.8	46.7	50.0	39.7	40.5	43.3	46.3
	S/T	0.91	0.85	0.69	0.52	0.94	0.88	0.72	0.54	0.97	0.91	0.74	0.55	1.00	0.94	0.76	0.57	1.00	0.97	0.79	0.59	1.00	0.98	0.80	0.60
	ΔT	23	22	19	15	23	22	20	16	23	22	20	16	24	23	20	16	22	22	19	16	21	21	18	14
kW	2.85	2.91	3.01	3.10	3.07	3.14	3.24	3.35	3.27	3.34	3.45	3.57	3.44	3.52	3.64	3.76	3.59	3.67	3.80	3.93	3.72	3.80	3.93	4.07	
Amps	10.1	10.4	10.7	11.1	11.0	11.2	11.6	12.1	12.0	12.3	12.7	13.2	12.8	13.2	13.6	14.2	13.7	14.0	14.5	15.1	14.5	14.9	15.4	16.0	
HI PR	225	242	246	251	255	274	278	284	290	311	316	323	330	355	360	368	371	399	405	414	416	447	453	463	
Lo PR	119	123	134	143	123	127	138	147	127	131	143	152	130	135	147	156	133	137	150	160	136	141	154	163	
MBh	44.7	45.7	48.8	52.2	43.7	44.6	47.7	51.0	42.6	43.6	46.6	49.8	41.6	42.5	45.4	48.6	39.5	40.4	43.1	46.1	36.6	37.4	40.0	42.7	
S/T	0.88	0.82	0.67	0.50	0.91	0.85	0.69	0.52	0.93	0.87	0.71	0.53	0.96	0.90	0.73	0.55	1.00	0.94	0.76	0.57	1.01	0.94	0.77	0.57	
ΔT	24	23	20	16	24	23	20	16	24	23	20	16	24	23	20	16	24	23	20	16	22	21	18	15	
kW	2.83	2.89	2.98	3.08	3.05	3.12	3.22	3.32	3.24	3.32	3.43	3.54	3.42	3.49	3.61	3.73	3.56	3.64	3.76	3.89	3.69	3.77	3.90	4.03	
Amps	10.0	10.3	10.6	11.0	10.9	11.1	11.5	12.0	11.9	12.2	12.6	13.1	12.7	13.0	13.5	14.0	13.6	13.9	14.4	15.0	14.4	14.8	15.3	15.9	
HI PR	223	240	243	249	252	271	275	281	287	308	313	320	327	351	356	364	367	395	401	409	411	442	449	459	
Lo PR	118	122	133	142	122	125	137	146	126	130	142	151	129	133	145	155	132	136	148	158	135	139	152	162	

85	MBh	50.8	51.8	54.2	57.8	49.6	50.6	53.0	56.5	48.4	49.4	51.7	55.1	47.2	48.2	50.4	53.8	44.9	45.7	47.9	51.1	41.6	42.4	44.4	47.3
	S/T	1.00	0.97	0.87	0.71	1.00	1.00	0.90	0.73	1.00	1.00	0.93	0.75	1.00	1.00	0.96	0.78	1.00	1.00	0.99	0.80	1.00	1.00	1.00	0.81
	ΔT	24	23	22	19	23	24	22	19	23	23	22	19	22	22	22	19	21	21	21	19	19	20	21	18
	kW	2.87	2.94	3.03	3.13	3.10	3.17	3.27	3.38	3.30	3.37	3.48	3.60	3.47	3.55	3.67	3.80	3.62	3.70	3.83	3.96	3.75	3.84	3.97	4.10
	Amps	10.2	10.5	10.8	11.2	11.1	11.4	11.7	12.2	12.1	12.4	12.8	13.3	13.0	13.3	13.7	14.3	13.8	14.2	14.7	15.3	14.7	15.1	15.6	16.2
	HI PR	228	245	248	254	257	277	280	287	292	315	319	326	333	358	363	371	375	403	409	418	420	451	458	468
	Lo PR	121	124	136	145	124	128	140	149	128	132	145	154	132	136	148	158	134	139	151	161	138	142	155	165
	MBh	49.3	50.3	52.6	56.2	48.2	49.1	51.4	54.8	47.0	47.9	50.2	53.5	45.9	46.7	49.0	52.2	43.6	44.4	46.5	49.6	40.4	41.1	43.1	46.0
	S/T	0.95	0.92	0.83	0.67	0.99	0.95	0.86	0.70	1.00	0.98	0.88	0.72	1.00	1.00	0.91	0.74	1.00	1.00	0.95	0.77	1.00	1.00	0.95	0.77
	ΔT	25	24	23	20	25	25	23	20	25	25	23	20	24	25	23	20	23	23	23	20	21	22	22	19
kW	2.85	2.91	3.01	3.10	3.07	3.14	3.24	3.35	3.27	3.34	3.45	3.57	3.44	3.52	3.64	3.76	3.59	3.67	3.80	3.93	3.72	3.80	3.93	4.07	
Amps	10.1	10.4	10.7	11.1	11.0	11.2	11.6	12.1	12.0	12.3	12.7	13.2	12.8	13.2	13.6	14.2	13.7	14.0	14.5	15.1	14.5	14.9	15.4	16.0	
HI PR	225	242	246	251	255	274	278	284	290	311	316	323	330	355	360	368	371	399	405	414	416	447	453	463	
Lo PR	119	123	134	143	123	127	138	147	127	131	143	152	130	135	147	156	133	137	150	160	136	141	154	163	
MBh	45.5	46.4	48.6	51.8	44.4	45.3	47.5	50.6	43.4	44.2	46.3	49.4	42.3	43.1	45.2	48.2	40.2	41.0	42.9	45.8	37.3	38.0	39.8	42.4	
S/T	0.92	0.89	0.80	0.65	0.95	0.92	0.83	0.67	0.98	0.94	0.85	0.69	1.00	0.97	0.88	0.71	1.00	1.00	0.91	0.74	1.00	1.00	0.92	0.75	
ΔT	25	25	23	20	25	25	24	20	25	25	24	21	25	25	24	21	24	25	24	20	22	23	22	19	
kW	2.83	2.89	2.98	3.08	3.05	3.12	3.22	3.32	3.24	3.32	3.43	3.54	3.42	3.49	3.61	3.73	3.56	3.64	3.76	3.89	3.69	3.77	3.90	4.03	
Amps	10.0	10.3	10.6	11.0	10.9	11.1	11.5	12.0	11.9	12.2	12.6	13.1	12.7	13.0	13.5	14.0	13.6	13.9	14.4	15.0	14.4	14.8	15.3	15.9	
HI PR	223	240	243	249	252	271	275	281	287	308	313	320	327	351	356	364	367	395	401	409	411	442	449	459	
Lo PR	118	122	133	142	122	125	137	146	126	130	142	151	129	133	145	155	132	136	148	158	135	139	152	162	

IDB = Entering Indoor Dry Bulb Temperature  
 High and low pressures are measured at the liquid and suction service valves.  
 Shaded area is AHRI (TVA) conditions  
 kW = Total system power  
 Amps = outdoor unit amps (comp.+fan)

IDB	AIRFLOW	OUTDOOR AMBIENT TEMPERATURE												ENTERING INDOOR WET BULB TEMPERATURE											
		65°F				75°F				85°F				95°F				105°F				115°F			
		59	63	67	71	59	63	67	71	59	63	67	71	59	63	67	71	59	63	67	71	59	63	67	71
70	MBh	42.4	43.9	48.1	-	41.4	42.9	47.0	-	40.4	41.9	45.9	-	39.4	40.8	44.7	-	37.4	38.8	42.5	-	34.7	35.9	39.4	-
	S/T	0.73	0.61	0.42	-	0.75	0.63	0.44	-	0.77	0.65	0.45	-	0.80	0.67	0.46	-	0.83	0.69	0.48	-	0.83	0.70	0.48	-
	ΔT	19	16	12	-	19	16	12	-	19	16	12	-	19	16	12	-	19	16	12	-	17	15	11	-
	kW	2.43	2.49	2.57	-	2.64	2.70	2.79	-	2.82	2.89	2.99	-	2.98	3.05	3.16	-	3.12	3.19	3.31	-	3.24	3.31	3.43	-
	Amps	9.4	9.6	10.0	-	10.2	10.4	10.8	-	11.1	11.4	11.8	-	11.9	12.2	12.6	-	14.0	14.3	14.8	-	14.8	15.1	15.7	-
	HI PR	226	243	247	-	248	267	271	-	291	313	317	-	331	356	361	-	372	400	406	-	430	463	469	-
	Lo PR	118	122	133	-	121	125	137	-	125	129	141	-	129	133	145	-	131	136	148	-	135	139	152	-
	MBh	41.1	42.6	46.7	-	40.2	41.6	45.6	-	39.2	40.6	44.5	-	38.3	39.6	43.4	-	36.3	37.7	41.3	-	33.7	34.9	38.2	-
	S/T	0.69	0.58	0.40	-	0.72	0.60	0.42	-	0.74	0.62	0.43	-	0.76	0.64	0.44	-	0.79	0.66	0.46	-	0.80	0.66	0.46	-
	ΔT	19	17	13	-	20	17	13	-	20	17	13	-	20	17	13	-	20	17	13	-	18	16	12	-
	kW	2.41	2.47	2.55	-	2.61	2.68	2.77	-	2.80	2.86	2.96	-	2.95	3.03	3.13	-	3.09	3.16	3.28	-	3.21	3.28	3.40	-
	Amps	9.3	9.5	9.9	-	10.1	10.3	10.7	-	11.0	11.3	11.7	-	11.8	12.1	12.5	-	13.8	14.2	14.7	-	14.6	15.0	15.5	-
HI PR	224	241	244	-	246	264	268	-	288	309	314	-	328	352	357	-	369	397	402	-	426	458	465	-	
Lo PR	117	120	131	-	120	124	135	-	124	128	140	-	128	132	144	-	130	134	146	-	133	137	150	-	
MBh	38.0	39.3	43.1	-	37.1	38.4	42.1	-	36.2	37.5	41.1	-	35.3	36.6	40.1	-	33.5	34.8	38.1	-	31.1	32.2	35.3	-	
S/T	0.67	0.56	0.39	-	0.69	0.58	0.40	-	0.71	0.59	0.41	-	0.73	0.61	0.42	-	0.76	0.64	0.44	-	0.77	0.64	0.44	-	
ΔT	20	17	13	-	20	17	13	-	20	17	13	-	20	17	13	-	20	17	13	-	19	16	12	-	
kW	2.39	2.44	2.53	-	2.59	2.65	2.75	-	2.77	2.84	2.94	-	2.93	3.00	3.10	-	3.06	3.14	3.25	-	3.18	3.25	3.37	-	
Amps	9.2	9.4	9.8	-	10.0	10.2	10.6	-	10.9	11.2	11.6	-	11.7	12.0	12.4	-	13.7	14.0	14.5	-	14.5	14.8	15.4	-	
HI PR	222	238	242	-	243	262	265	-	285	306	311	-	325	349	354	-	365	393	398	-	422	454	460	-	
Lo PR	116	119	130	-	119	123	134	-	123	127	138	-	126	130	142	-	129	133	145	-	132	136	149	-	

75	MBh	43.1	44.3	48.0	51.5	42.1	43.3	46.9	50.3	41.1	42.3	45.8	49.1	40.1	41.3	44.7	47.9	38.1	39.2	42.4	45.5	35.3	36.3	39.3	42.2
	S/T	0.83	0.74	0.56	0.36	0.86	0.77	0.58	0.37	0.88	0.79	0.59	0.38	0.91	0.81	0.61	0.39	0.94	0.84	0.64	0.41	0.95	0.85	0.64	0.41
	ΔT	22	20	16	11	22	20	16	11	22	20	16	11	22	20	17	11	22	20	16	11	20	19	15	11
	kW	2.43	2.49	2.57	2.67	2.64	2.70	2.79	2.89	2.82	2.89	2.99	3.10	2.98	3.05	3.16	3.28	3.12	3.19	3.31	3.43	3.24	3.31	3.43	3.56
	Amps	9.4	9.6	10.0	10.3	10.2	10.4	10.8	11.2	11.1	11.4	11.8	12.2	11.9	12.2	12.6	13.1	14.0	14.3	14.8	15.4	14.8	15.1	15.7	16.3
	HI PR	226	243	247	252	248	267	271	277	291	313	317	324	331	356	361	369	372	400	406	415	430	463	469	480
	Lo PR	118	122	133	141	121	125	137	146	125	129	141	150	129	133	145	154	131	136	148	158	135	139	152	161
	MBh	41.8	43.1	46.6	50.0	40.8	42.1	45.5	48.9	39.9	41.1	44.4	47.7	38.9	40.1	43.4	46.5	37.0	38.0	41.2	44.2	34.2	35.2	38.1	40.9
	S/T	0.79	0.70	0.53	0.34	0.82	0.73	0.55	0.36	0.84	0.75	0.57	0.36	0.86	0.77	0.59	0.38	0.90	0.80	0.61	0.39	0.90	0.81	0.61	0.39
	ΔT	22	21	17	12	23	21	17	12	23	21	17	12	23	21	17	12	23	21	17	12	21	19	16	11
	kW	2.41	2.47	2.55	2.64	2.61	2.68	2.77	2.87	2.80	2.86	2.96	3.07	2.95	3.03	3.13	3.25	3.09	3.16	3.28	3.40	3.21	3.28	3.40	3.53
	Amps	9.3	9.5	9.9	10.2	10.1	10.3	10.7	11.1	11.0	11.3	11.7	12.1	11.8	12.1	12.5	13.0	13.8	14.2	14.7	15.3	14.6	15.0	15.5	16.1
HI PR	224	241	244	250	246	264	268	274	288	309	314	321	328	352	357	365	369	397	402	411	426	458	465	475	
Lo PR	117	120	131	140	120	124	135	144	124	128	140	149	128	132	144	153	130	134	146	156	133	137	150	160	
MBh	38.6	39.7	43.0	46.2	37.7	38.8	42.0	45.1	36.8	37.9	41.0	44.0	35.9	37.0	40.0	42.9	34.1	35.1	38.0	40.8	31.6	32.5	35.2	37.8	
S/T	0.76	0.68	0.51	0.33	0.79	0.70	0.53	0.34	0.81	0.72	0.55	0.35	0.83	0.75	0.56	0.36	0.87	0.77	0.59	0.38	0.87	0.78	0.59	0.38	
ΔT	23	21	17	12	23	21	17	12	23	21	17	12	23	21	18	12	23	21	17	12	21	20	16	11	
kW	2.39	2.44	2.53	2.62	2.59	2.65	2.75	2.84	2.77	2.84	2.94	3.04	2.93	3.00	3.10	3.22	3.06	3.14	3.25	3.37	3.18	3.25	3.37	3.49	
Amps	9.2	9.4	9.8	10.1	10.0	10.2	10.6	11.0	10.9	11.2	11.6	12.0	11.7	12.0	12.4	12.9	13.7	14.0	14.5	15.1	14.5	14.8	15.4	16.0	
HI PR	222	238	242	247	243	262	265	271	285	306	311	318	325	349	354	362	365	393	398	407	422	454	460	470	
Lo PR	116	119	130	139	119	123	134	143	123	127	138	147	126	130	142	151	129	133	145	154	132	136	149	158	

IDB = Entering Indoor Dry Bulb Temperature  
 High and low pressures are measured at the liquid and suction service valves.  
 Shaded area is ACCA (TVA) conditions  
 kW = Total system power  
 Amps = outdoor unit amps (comp.+fan)

IDB	AIRFLOW	OUTDOOR AMBIENT TEMPERATURE												ENTERING INDOOR WET BULB TEMPERATURE											
		65°F				75°F				85°F				95°F				105°F				115°F			
		59	63	67	71	59	63	67	71	59	63	67	71	59	63	67	71	59	63	67	71	59	63	67	71
80	MBh	43.8	44.8	47.9	51.2	42.8	43.8	46.7	50.0	41.8	42.7	45.6	48.8	40.8	41.7	44.5	47.6	38.7	39.6	42.3	45.2	35.9	36.7	39.2	41.9
	S/T	0.91	0.85	0.69	0.52	0.94	0.88	0.72	0.54	0.96	0.90	0.74	0.55	1.00	0.93	0.76	0.57	1.00	0.97	0.79	0.59	1.00	1.00	0.79	0.59
	ΔT	24	23	20	16	24	23	20	16	24	23	20	16	25	23	20	16	23	23	20	16	22	22	19	15
	kW	2.43	2.49	2.57	2.67	2.64	2.70	2.79	2.89	2.82	2.89	2.99	3.10	2.98	3.05	3.16	3.28	3.12	3.19	3.31	3.43	3.24	3.31	3.43	3.56
	Amps	9.4	9.6	10.0	10.3	10.2	10.4	10.8	11.2	11.1	11.4	11.8	12.2	11.9	12.2	12.6	13.1	14.0	14.3	14.8	15.4	14.8	15.1	15.7	16.3
	HI PR	226	243	247	252	248	267	271	277	291	313	317	324	331	356	361	369	372	400	406	415	430	463	469	480
	Lo PR	118	122	133	141	121	125	137	146	125	129	141	150	129	133	145	154	131	136	148	158	135	139	152	161
	MBh	42.6	43.5	46.5	49.7	41.6	42.5	45.4	48.5	40.6	41.5	44.3	47.4	39.6	40.5	43.2	46.2	37.6	38.4	41.1	43.9	34.8	35.6	38.0	40.7
	S/T	0.86	0.81	0.66	0.49	0.90	0.84	0.68	0.51	0.92	0.86	0.70	0.52	0.95	0.89	0.72	0.54	0.98	0.92	0.75	0.56	0.99	0.93	0.76	0.57
	ΔT	25	24	21	17	25	24	21	17	25	24	21	17	26	24	21	17	25	24	21	17	24	23	20	16
kW	2.41	2.47	2.55	2.64	2.61	2.68	2.77	2.87	2.80	2.86	2.96	3.07	2.95	3.03	3.13	3.25	3.09	3.16	3.28	3.40	3.21	3.28	3.40	3.53	
Amps	9.3	9.5	9.9	10.2	10.1	10.3	10.7	11.1	11.0	11.3	11.7	12.1	11.8	12.1	12.5	13.0	13.8	14.2	14.7	15.3	14.6	15.0	15.5	16.1	
HI PR	224	241	244	250	246	264	268	274	288	309	314	321	328	352	357	365	369	397	402	411	426	458	465	475	
Lo PR	117	120	131	140	120	124	135	144	124	128	140	149	128	132	144	153	130	134	146	156	133	137	150	160	
MBh	39.3	40.1	42.9	45.8	38.4	39.2	41.9	44.8	37.5	38.3	40.9	43.7	36.5	37.3	39.9	42.6	34.7	35.5	37.9	40.5	32.2	32.9	35.1	37.5	
S/T	0.83	0.78	0.64	0.48	0.86	0.81	0.66	0.49	0.89	0.83	0.68	0.51	0.91	0.86	0.70	0.52	0.95	0.89	0.72	0.54	0.96	0.90	0.73	0.55	
ΔT	26	24	21	17	26	25	22	17	26	25	22	17	26	25	22	17	26	25	21	17	24	23	20	16	
kW	2.39	2.44	2.53	2.62	2.59	2.65	2.75	2.84	2.77	2.84	2.94	3.04	2.93	3.00	3.10	3.22	3.06	3.14	3.25	3.37	3.18	3.25	3.37	3.49	
Amps	9.2	9.4	9.8	10.1	10.0	10.2	10.6	11.0	10.9	11.2	11.6	12.0	11.7	12.0	12.4	12.9	13.7	14.0	14.5	15.1	14.5	14.8	15.4	16.0	
HI PR	222	238	242	247	243	262	265	271	285	306	311	318	325	349	354	362	365	393	398	407	422	454	460	470	
Lo PR	116	119	130	139	119	123	134	143	123	127	138	147	126	130	142	151	129	133	145	154	132	136	149	158	

85	MBh	44.6	45.5	47.6	50.8	43.6	44.4	46.5	49.6	42.5	43.4	45.4	48.4	41.5	42.3	44.3	47.3	39.4	40.2	42.1	44.9	36.5	37.2	39.0	41.6
	S/T	0.95	0.92	0.83	0.67	0.98	0.95	0.86	0.70	1.00	0.97	0.88	0.71	1.00	1.00	0.91	0.74	1.00	1.00	0.94	0.76	1.00	1.00	0.95	0.77
	ΔT	26	25	24	21	26	26	24	21	26	26	24	21	25	26	24	21	24	24	24	21	22	23	22	19
	kW	2.43	2.49	2.57	2.67	2.64	2.70	2.79	2.89	2.82	2.89	2.99	3.10	2.98	3.05	3.16	3.28	3.12	3.19	3.31	3.43	3.24	3.31	3.43	3.56
	Amps	9.4	9.6	10.0	10.3	10.2	10.4	10.8	11.2	11.1	11.4	11.8	12.2	11.9	12.2	12.6	13.1	14.0	14.3	14.8	15.4	14.8	15.1	15.7	16.3
	HI PR	226	243	247	252	248	267	271	277	291	313	317	324	331	356	361	369	372	400	406	415	430	463	469	480
	Lo PR	118	122	133	141	121	125	137	146	125	129	141	150	129	133	145	154	131	136	148	158	135	139	152	161
	MBh	43.3	44.1	46.2	49.3	42.3	43.1	45.2	48.2	41.3	42.1	44.1	47.0	40.3	41.1	43.0	45.9	38.3	39.0	40.9	43.6	35.4	36.1	37.8	40.4
	S/T	0.91	0.87	0.79	0.64	0.94	0.91	0.82	0.66	0.96	0.93	0.84	0.68	0.99	0.96	0.87	0.70	1.00	1.00	0.90	0.73	1.00	1.00	0.91	0.73
	ΔT	27	26	25	22	27	27	25	22	27	27	25	22	27	27	25	22	26	26	25	22	24	25	23	20
kW	2.41	2.47	2.55	2.64	2.61	2.68	2.77	2.87	2.80	2.86	2.96	3.07	2.95	3.03	3.13	3.25	3.09	3.16	3.28	3.40	3.21	3.28	3.40	3.53	
Amps	9.3	9.5	9.9	10.2	10.1	10.3	10.7	11.1	11.0	11.3	11.7	12.1	11.8	12.1	12.5	13.0	13.8	14.2	14.7	15.3	14.6	15.0	15.5	16.1	
HI PR	224	241	244	250	246	264	268	274	288	309	314	321	328	352	357	365	369	397	402	411	426	458	465	475	
Lo PR	117	120	131	140	120	124	135	144	124	128	140	149	128	132	144	153	130	134	146	156	133	137	150	160	
MBh	40.0	40.7	42.7	45.5	39.0	39.8	41.7	44.5	38.1	38.8	40.7	43.4	37.2	37.9	39.7	42.3	35.3	36.0	37.7	40.2	32.7	33.4	34.9	37.3	
S/T	0.87	0.84	0.76	0.62	0.91	0.87	0.79	0.64	0.93	0.90	0.81	0.66	0.96	0.92	0.83	0.68	0.99	0.96	0.87	0.70	1.00	0.97	0.87	0.71	
ΔT	27.2	27	25	22	28	27	26	22	28	27	26	22	28	27	26	22	27	27	25	22	25	25	24	21	
kW	2.39	2.44	2.53	2.62	2.59	2.65	2.75	2.84	2.77	2.84	2.94	3.04	2.93	3.00	3.10	3.22	3.06	3.14	3.25	3.37	3.18	3.25	3.37	3.49	
Amps	9.2	9.4	9.8	10.1	10.0	10.2	10.6	11.0	10.9	11.2	11.6	12.0	11.7	12.0	12.4	12.9	13.7	14.0	14.5	15.1	14.5	14.8	15.4	16.0	
HI PR	222	238	242	247	243	262	265	271	285	306	311	318	325	349	354	362	365	393	398	407	422	454	460	470	
Lo PR	116	119	130	139	119	123	134	143	123	127	138	147	126	130	142	151	129	133	145	154	132	136	149	158	

kW = Total system power  
Amps = outdoor unit amps (comp.+fan)

Shaded area is AHRI (TVA) conditions

IDB = Entering Indoor Dry Bulb Temperature  
High and low pressures are measured at the liquid and suction service valves.

IDB		OUTDOOR AMBIENT TEMPERATURE												ENTERING INDOOR WET BULB TEMPERATURE											
		65°F				75°F				85°F				95°F				105°F				115°F			
		59	63	67	71	59	63	67	71	59	63	67	71	59	63	67	71	59	63	67	71	59	63	67	71
70	MBh	58.5	60.6	66.4	-	57.1	59.2	64.9	-	55.8	57.8	63.3	-	54.4	56.4	61.8	-	51.7	53.6	58.7	-	47.9	49.6	54.4	-
	S/T	0.73	0.61	0.42	-	0.76	0.63	0.44	-	0.78	0.65	0.45	-	0.80	0.67	0.47	-	0.83	0.70	0.48	-	0.84	0.70	0.49	-
	ΔT	18	15	12	-	18	15	12	-	18	15	12	-	18	15	12	-	18	15	12	-	16	14	11	-
	kW	3.87	3.96	4.09	-	4.18	4.27	4.41	-	4.45	4.55	4.70	-	4.69	4.80	4.96	-	4.89	5.00	5.17	-	5.07	5.18	5.36	-
	Amps	13.8	14.2	14.7	-	15.0	15.4	15.9	-	16.4	16.8	17.4	-	17.6	18.0	18.7	-	20.6	21.2	21.9	-	21.8	22.4	23.2	-
	HI PR	241	259	263	-	265	285	289	-	310	333	338	-	353	380	385	-	397	427	433	-	459	493	500	-
	Lo PR	115	119	130	-	118	122	133	-	123	126	138	-	126	130	142	-	128	132	144	-	131	136	148	-
	MBh	56.8	58.9	64.5	-	55.5	57.5	63.0	-	54.2	56.1	61.5	-	52.8	54.8	60.0	-	50.2	52.0	57.0	-	46.5	48.2	52.8	-
	S/T	0.70	0.58	0.40	-	0.72	0.60	0.42	-	0.74	0.62	0.43	-	0.77	0.64	0.44	-	0.80	0.66	0.46	-	0.80	0.67	0.46	-
	ΔT	18	16	12	-	18	16	12	-	18	16	12	-	19	16	12	-	18	16	12	-	17	15	11	-
kW	3.84	3.93	4.05	-	4.15	4.24	4.38	-	4.41	4.51	4.66	-	4.65	4.75	4.91	-	4.85	4.96	5.13	-	5.02	5.14	5.31	-	
Amps	13.7	14.0	14.5	-	14.9	15.2	15.8	-	16.2	16.6	17.2	-	17.4	17.8	18.5	-	20.4	21.0	21.7	-	21.6	22.2	23.0	-	
HI PR	239	257	260	-	262	282	286	-	307	330	335	-	349	376	381	-	393	423	429	-	454	488	495	-	
Lo PR	114	118	128	-	117	121	132	-	121	125	137	-	125	128	140	-	127	131	143	-	130	134	147	-	
MBh	52.4	54.3	59.5	-	51.2	53.1	58.1	-	50.0	51.8	56.8	-	48.8	50.5	55.4	-	46.3	48.0	52.6	-	42.9	44.5	48.7	-	
S/T	0.67	0.56	0.39	-	0.70	0.58	0.40	-	0.72	0.60	0.41	-	0.74	0.62	0.43	-	0.77	0.64	0.44	-	0.77	0.65	0.45	-	
ΔT	19	16	12	-	19	16	12	-	19	16	12	-	19	16	12	-	19	16	12	-	17	15	11	-	
kW	3.81	3.89	4.02	-	4.11	4.20	4.34	-	4.38	4.47	4.62	-	4.61	4.71	4.87	-	4.81	4.92	5.08	-	4.98	5.09	5.27	-	
Amps	13.5	13.9	14.4	-	14.7	15.1	15.6	-	16.1	16.5	17.1	-	17.2	17.7	18.3	-	20.2	20.8	21.5	-	21.4	22.0	22.7	-	
HI PR	236	254	258	-	259	279	283	-	304	327	331	-	346	372	377	-	389	419	424	-	450	484	490	-	
Lo PR	113	116	127	-	116	120	131	-	120	124	135	-	123	127	139	-	126	130	142	-	129	133	145	-	

IDB		OUTDOOR AMBIENT TEMPERATURE												ENTERING INDOOR WET BULB TEMPERATURE											
		65°F				75°F				85°F				95°F				105°F				115°F			
		59	63	67	71	59	63	67	71	59	63	67	71	59	63	67	71	59	63	67	71	59	63	67	71
75	MBh	59.5	61.3	66.3	71.2	58.1	59.8	64.8	69.5	56.7	58.4	63.2	67.8	55.3	57.0	61.7	66.2	52.6	54.1	58.6	62.9	48.7	50.1	54.3	58.3
	S/T	0.83	0.75	0.56	0.36	0.86	0.77	0.58	0.38	0.89	0.79	0.60	0.39	0.91	0.82	0.62	0.40	0.95	0.85	0.64	0.41	0.96	0.86	0.65	0.42
	ΔT	20	19	15	11	20	19	15	11	21	19	15	11	21	19	16	11	20	19	15	11	19	18	14	10
	kW	3.87	3.96	4.09	4.22	4.18	4.27	4.41	4.56	4.45	4.55	4.70	4.86	4.69	4.80	4.96	5.13	4.89	5.00	5.17	5.35	5.07	5.18	5.36	5.55
	Amps	13.8	14.2	14.7	15.2	15.0	15.4	15.9	16.6	16.4	16.8	17.4	18.1	17.6	18.0	18.7	19.4	20.6	21.2	21.9	22.8	21.8	22.4	23.2	24.1
	HI PR	241	259	263	269	265	285	289	295	310	333	338	345	353	380	385	393	397	427	433	443	459	493	500	511
	Lo PR	115	119	130	138	118	122	133	142	123	126	138	147	126	130	142	151	128	132	144	154	131	136	148	158
	MBh	57.8	59.5	64.4	69.1	56.4	58.1	62.9	67.5	55.1	56.7	61.4	65.9	53.7	55.3	59.9	64.3	51.0	52.6	56.9	61.1	47.3	48.7	52.7	56.6
	S/T	0.79	0.71	0.54	0.35	0.82	0.74	0.56	0.36	0.84	0.76	0.57	0.37	0.87	0.78	0.59	0.38	0.90	0.81	0.61	0.39	0.91	0.82	0.62	0.40
	ΔT	21	19	16	11	21	20	16	11	21	20	16	11	22	20	16	11	21	20	16	11	20	18	15	10
kW	3.84	3.93	4.05	4.19	4.15	4.24	4.38	4.52	4.41	4.51	4.66	4.82	4.65	4.75	4.91	5.08	4.85	4.96	5.13	5.31	5.02	5.14	5.31	5.50	
Amps	13.7	14.0	14.5	15.1	14.9	15.2	15.8	16.4	16.2	16.6	17.2	17.9	17.4	17.8	18.5	19.2	20.4	21.0	21.7	22.6	21.6	22.2	23.0	23.9	
HI PR	239	257	260	266	262	282	286	292	307	330	335	342	349	376	381	389	393	423	429	438	454	488	495	506	
Lo PR	114	118	128	137	117	121	132	141	121	125	137	145	125	128	140	149	127	131	143	152	130	134	147	156	
MBh	53.3	54.9	59.4	63.8	52.1	53.6	58.0	62.3	50.8	52.3	56.7	60.8	49.6	51.1	55.3	59.3	47.1	48.5	52.5	56.4	43.6	44.9	48.6	52.2	
S/T	0.77	0.69	0.52	0.33	0.79	0.71	0.54	0.35	0.81	0.73	0.55	0.35	0.84	0.75	0.57	0.37	0.87	0.78	0.59	0.38	0.88	0.79	0.60	0.38	
ΔT	21	20	16	11	22	20	16	11	22	20	16	11	22	20	17	11	22	20	16	11	20	19	15	11	
kW	3.81	3.89	4.02	4.15	4.11	4.20	4.34	4.49	4.38	4.47	4.62	4.78	4.61	4.71	4.87	5.04	4.81	4.92	5.08	5.26	4.98	5.09	5.27	5.45	
Amps	13.5	13.9	14.4	14.9	14.7	15.1	15.6	16.2	16.1	16.5	17.1	17.7	17.2	17.7	18.3	19.0	20.2	20.8	21.5	22.3	21.4	22.0	22.7	23.6	
HI PR	236	254	258	263	259	279	283	289	304	327	331	339	346	372	377	386	389	419	424	434	450	484	490	501	
Lo PR	113	116	127	135	116	120	131	139	120	124	135	144	123	127	139	148	126	130	142	151	129	133	145	155	

IDB = Entering Indoor Dry Bulb Temperature  
 High and low pressures are measured at the liquid and suction service valves.  
 Shaded area is ACCA (TVA) conditions  
 kW = Total system power  
 Amps = outdoor unit amps (comp.+fan)

IDB	AIRFLOW	OUTDOOR AMBIENT TEMPERATURE												ENTERING INDOOR WET BULB TEMPERATURE											
		65°F				75°F				85°F				95°F				105°F				115°F			
		59	63	67	71	59	63	67	71	59	63	67	71	59	63	67	71	59	63	67	71	59	63	67	71
80	MBh	60.6	61.9	66.1	70.7	59.1	60.4	64.6	69.0	57.7	59.0	63.0	67.4	56.3	57.6	61.5	65.7	53.5	54.7	58.4	62.4	49.6	50.6	54.1	57.8
	S/T	0.91	0.86	0.70	0.52	0.95	0.89	0.72	0.54	1.00	0.91	0.74	0.55	1.00	0.94	0.77	0.57	1.00	1.00	0.79	0.59	1.00	1.00	0.80	0.60
	ΔT	23	22	19	15	23	22	19	15	24	22	19	15	23	22	19	15	22	22	19	15	20	21	18	14
	kW	3.87	3.96	4.09	4.22	4.18	4.27	4.41	4.56	4.45	4.55	4.70	4.86	4.69	4.80	4.96	5.13	4.89	5.00	5.17	5.35	5.07	5.18	5.36	5.55
	Amps	13.8	14.2	14.7	15.2	15.0	15.4	15.9	16.6	16.4	16.8	17.4	18.1	17.6	18.0	18.7	19.4	20.6	21.2	21.9	22.8	21.8	22.4	23.2	24.1
	HI PR	241	259	263	269	265	285	289	295	310	333	338	345	353	380	385	393	397	427	433	443	459	493	500	511
	Lo PR	115	119	130	138	118	122	133	142	123	126	138	147	126	130	142	151	128	132	144	154	131	136	148	158
	MBh	58.8	60.1	64.2	68.6	57.4	58.7	62.7	67.0	56.1	57.3	61.2	65.4	54.7	55.9	59.7	63.8	52.0	53.1	56.7	60.6	48.1	49.2	52.5	56.2
	S/T	0.87	0.82	0.67	0.50	0.90	0.85	0.69	0.52	0.93	0.87	0.71	0.53	0.96	0.90	0.73	0.55	0.99	0.93	0.76	0.57	1.00	0.94	0.76	0.57
	ΔT	24	23	20	16	24	23	20	16	24	23	20	16	24	23	20	16	24	23	20	16	22	21	18	15
kW	3.84	3.93	4.05	4.19	4.15	4.24	4.38	4.52	4.41	4.51	4.66	4.82	4.65	4.75	4.91	5.08	4.85	4.96	5.13	5.31	5.02	5.14	5.31	5.50	
Amps	13.7	14.0	14.5	15.1	14.9	15.2	15.8	16.4	16.2	16.6	17.2	17.9	17.4	17.8	18.5	19.2	20.4	21.0	21.7	22.6	21.6	22.2	23.0	23.9	
HI PR	239	257	260	266	262	282	286	292	307	330	335	342	349	376	381	389	393	423	429	438	454	488	495	506	
Lo PR	114	118	128	137	117	121	132	141	121	125	137	145	125	128	140	149	127	131	143	152	130	134	147	156	
MBh	54.3	55.4	59.2	63.3	53.0	54.2	57.9	61.9	51.7	52.9	56.5	60.4	50.5	51.6	55.1	58.9	48.0	49.0	52.3	56.0	44.4	45.4	48.5	51.8	
S/T	0.84	0.79	0.64	0.48	0.87	0.82	0.66	0.50	0.89	0.84	0.68	0.51	0.92	0.86	0.70	0.53	0.96	0.90	0.73	0.55	0.96	0.90	0.74	0.55	
ΔT	24	23	20	16	24	23	20	16	24	23	20	16	24	23	20	16	24	23	20	16	23	22	19	15	
kW	3.81	3.89	4.02	4.15	4.11	4.20	4.34	4.49	4.38	4.47	4.62	4.78	4.61	4.71	4.87	5.04	4.81	4.92	5.08	5.26	4.98	5.09	5.27	5.45	
Amps	13.5	13.9	14.4	14.9	14.7	15.1	15.6	16.2	16.1	16.5	17.1	17.7	17.2	17.7	18.3	19.0	20.2	20.8	21.5	22.3	21.4	22.0	22.7	23.6	
HI PR	236	254	258	263	259	279	283	289	304	327	331	339	346	372	377	386	389	419	424	434	450	484	490	501	
Lo PR	113	116	127	135	116	120	131	139	120	124	135	144	123	127	139	148	126	130	142	151	129	133	145	155	

85	MBh	61.6	62.8	65.8	70.2	60.2	61.3	64.2	68.5	58.7	59.9	62.7	66.9	57.3	58.4	61.2	65.3	54.4	55.5	58.1	62.0	50.4	51.4	53.8	57.4
	S/T	0.96	0.92	0.83	0.68	0.99	0.96	0.86	0.70	1.00	0.98	0.89	0.72	1.00	1.00	0.91	0.74	1.00	1.00	0.95	0.77	1.00	1.00	0.96	0.78
	ΔT	24	24	22	19	24	24	23	20	24	24	23	20	23	24	23	20	22	23	23	20	21	21	21	18
	kW	3.87	3.96	4.09	4.22	4.18	4.27	4.41	4.56	4.45	4.55	4.70	4.86	4.69	4.80	4.96	5.13	4.89	5.00	5.17	5.35	5.07	5.18	5.36	5.55
	Amps	13.8	14.2	14.7	15.2	15.0	15.4	15.9	16.6	16.4	16.8	17.4	18.1	17.6	18.0	18.7	19.4	20.6	21.2	21.9	22.8	21.8	22.4	23.2	24.1
	HI PR	241	259	263	269	265	285	289	295	310	333	338	345	353	380	385	393	397	427	433	443	459	493	500	511
	Lo PR	115	119	130	138	118	122	133	142	123	126	138	147	126	130	142	151	128	132	144	154	131	136	148	158
	MBh	59.8	61.0	63.9	68.1	58.4	59.6	62.4	66.5	57.0	58.1	60.9	65.0	55.6	56.7	59.4	63.4	52.9	53.9	56.4	60.2	49.0	49.9	52.3	55.8
	S/T	0.91	0.88	0.80	0.65	0.95	0.91	0.82	0.67	0.97	0.94	0.85	0.69	1.00	0.97	0.87	0.71	1.00	1.00	0.91	0.73	1.00	1.00	0.91	0.74
	ΔT	25	25	23	20	25	25	24	20	25	25	24	20	26	25	24	21	24	25	23	20	23	23	22	19
kW	3.84	3.93	4.05	4.19	4.15	4.24	4.38	4.52	4.41	4.51	4.66	4.82	4.65	4.75	4.91	5.08	4.85	4.96	5.13	5.31	5.02	5.14	5.31	5.50	
Amps	13.7	14.0	14.5	15.1	14.9	15.2	15.8	16.4	16.2	16.6	17.2	17.9	17.4	17.8	18.5	19.2	20.4	21.0	21.7	22.6	21.6	22.2	23.0	23.9	
HI PR	239	257	260	266	262	282	286	292	307	330	335	342	349	376	381	389	393	423	429	438	454	488	495	506	
Lo PR	114	118	128	137	117	121	132	141	121	125	137	145	125	128	140	149	127	131	143	152	130	134	147	156	
MBh	55.2	56.3	58.9	62.9	53.9	55.0	57.6	61.4	52.6	53.7	56.2	60.0	51.4	52.4	54.8	58.5	48.8	49.7	52.1	55.6	45.2	46.1	48.2	51.5	
S/T	0.88	0.85	0.77	0.62	0.91	0.88	0.79	0.64	0.94	0.90	0.82	0.66	0.97	0.93	0.84	0.68	1.00	0.97	0.87	0.71	1.00	0.98	0.88	0.71	
ΔT	26	25	24	21	26	25	24	21	26	25	24	21	26	26	24	21	26	25	24	21	24	24	22	19	
kW	3.81	3.89	4.02	4.15	4.11	4.20	4.34	4.49	4.38	4.47	4.62	4.78	4.61	4.71	4.87	5.04	4.81	4.92	5.08	5.26	4.98	5.09	5.27	5.45	
Amps	13.5	13.9	14.4	14.9	14.7	15.1	15.6	16.2	16.1	16.5	17.1	17.7	17.2	17.7	18.3	19.0	20.2	20.8	21.5	22.3	21.4	22.0	22.7	23.6	
HI PR	236	254	258	263	259	279	283	289	304	327	331	339	346	372	377	386	389	419	424	434	450	484	490	501	
Lo PR	113	116	127	135	116	120	131	139	120	124	135	144	123	127	139	148	126	130	142	151	129	133	145	155	

IDB = Entering Indoor Dry Bulb Temperature  
 High and low pressures are measured at the liquid and suction service valves.  
 Shaded area is AHRI (TVA) conditions  
 kW = Total system power  
 Amps = outdoor unit amps (comp.+fan)

OUTDOOR UNIT	INDOOR UNITS		COOLING RATINGS				CFM	AHRI #
	COILS/AIR HANDLERS	FURNACES	TOTAL <sup>1</sup>	SENS. <sup>1</sup>	SEER <sup>2</sup>	EER <sup>3</sup>		
ASXC18 0361A*	AVPTC42D14A*		35,000	26,600	17.00	13.00	1,280	5924393
	AVPTC48C14A*		34,000	25,800	16.00	12.50	1,100	7080497
	AVPTC48D14A*		36,000	27,400	17.50	13.00	1,200	5924394
	CA*F3743*6D*+EEP+TXV		35,000	26,600	15.00	12.50	1,250	5357237
	CA*F3743*6D*+MBVC1600**-1A*+TXV		35,000	26,600	18.00	13.00	1,200	4415258
	CA*F3743*6D*+MBVC2000**-1A*+TXV		35,000	26,600	18.00	13.00	1,200	4415259
	CA*F3743*6D*+TXV	A*VC80604B*B*	35,000	26,600	17.00	13.00	1,220	5188330
	CA*F3743*6D*+TXV	A*VC80805C*B*	35,000	26,600	17.00	13.00	1,190	5188331
	CA*F3743*6D*+TXV	A*VC81005C*B*	35,000	26,600	17.00	13.00	1,210	5188332
	CA*F3743*6D*+TXV	G*VC80604B*B*	35,000	26,600	17.00	13.00	1,220	5188333
	CA*F3743*6D*+TXV	G*VC80805C*B*	35,000	26,600	17.00	13.00	1,190	5188334
	CA*F3743*6D*+TXV	G*VC81005C*B*	35,000	26,600	17.00	13.00	1,210	5188335
	CA*F3743*6D*+TXV	ADVC80805C*B*	35,000	26,600	17.00	13.00	1,190	5188384
	CA*F3743*6D*+TXV	ADVC81005C*B*	35,000	26,600	17.00	13.00	1,230	5188440
	CA*F3743*6D*+TXV	G*VC960403BNA*	33,600	25,600	16.00	13.00	1,075	7363988
	CA*F3743*6D*+TXV	G*VC960603BNA*	33,600	25,600	16.00	13.00	1,075	7363993
	CA*F3743*6D*+TXV	G*VC960803BNA*	33,600	25,600	16.00	13.00	1,100	7363998
	CA*F3743*6D*+TXV	G*VC960804CNA*	34,400	26,200	17.00	13.00	1,190	7364003
	CA*F3743*6D*+TXV	G*VC961005CNA*	34,400	26,200	17.00	13.00	1,175	7364009
	CA*F3743*6D*+TXV	G*VC961205DNA*	34,600	26,200	17.00	13.00	1,150	7364015
	CA*F3743*6D*+TXV	G*VM970603BNA*	33,600	25,600	16.00	13.00	1,075	7364040
	CA*F3743*6D*+TXV	G*VM970803BNA*	33,600	25,600	16.00	13.00	1,100	7364045
	CA*F3743*6D*+TXV	G*VM970804CNA*	34,400	26,200	17.00	13.00	1,190	7364050
	CA*F3743*6D*+TXV	G*VM971005CNA*	34,400	26,200	17.00	13.00	1,175	7364056
	CA*F3743*6D*+TXV	G*VM971205DNA*	34,600	26,200	17.00	13.00	1,150	7364062
	CA*F3743*6D*+TXV	A*VC960403BNA*	33,600	25,600	16.00	13.00	1,075	7364087
	CA*F3743*6D*+TXV	A*VC960603BNA*	33,600	25,600	16.00	13.00	1,075	7364092
	CA*F3743*6D*+TXV	A*VC960803BNA*	33,600	25,600	16.00	13.00	1,100	7364097
	CA*F3743*6D*+TXV	A*VC960804CNA*	34,400	26,200	17.00	13.00	1,190	7364102
	CA*F3743*6D*+TXV	A*VC961005CNA*	34,400	26,200	17.00	13.00	1,175	7364108
	CA*F3743*6D*+TXV	A*VC961205DNA*	34,600	26,200	17.00	13.00	1,150	7364114
	CA*F3743*6D*+TXV	A*VM970603BNA*	33,600	25,600	16.00	13.00	1,075	7364139
	CA*F3743*6D*+TXV	A*VM970803BNA*	33,600	25,600	16.00	13.00	1,100	7364145
	CA*F3743*6D*+TXV	A*VM970804CNA*	34,400	26,200	17.00	13.00	1,190	7364150
	CA*F3743*6D*+TXV	A*VM971005CNA*	34,400	26,200	17.00	13.00	1,175	7364156
	CA*F3743*6D*+TXV	A*VM971205DNA*	34,600	26,200	17.00	13.00	1,150	7364162
	CA*F3743*6D*+TXV	G*EC960603BNA*	34,000	25,800	16.00	13.00	1,150	7368468
	CA*F3743*6D*+TXV	G*EC960803BNA*	34,000	25,800	16.00	12.50	1,150	7368472
	CA*F3743*6D*+TXV	G*EC961004CNA*	34,000	25,800	17.00	13.00	1,150	7368476
	CA*F3743*6D*+TXV	A*EC960603BNA*	34,000	25,800	16.00	13.00	1,150	7368489
	CA*F3743*6D*+TXV	A*EC960803BNA*	34,000	25,800	16.00	12.50	1,150	7368493
	CA*F3743*6D*+TXV	A*EC961004CNA*	34,000	25,800	17.00	13.00	1,150	7368497
	CA*F4860*6D*+MBVC2000**-1A*+TXV		36,000	27,400	19.00	13.50	1,250	3881445
	CA*F4961*6D*+EEP+TXV		36,000	27,400	15.00	12.50	1,250	5357238
	CA*F4961*6D*+MBVC1600**-1A*+TXV		36,000	27,400	17.50	13.00	1,200	6498294
	CA*F4961*6D*+MBVC2000**-1A*+TXV		36,000	27,400	19.00	13.50	1,250	4431458
	CA*F4961*6D*+TXV	A*VC80604B*B*	36,000	27,400	17.50	13.20	1,220	5188336
	CA*F4961*6D*+TXV	A*VC80805C*B*	36,000	27,400	18.00	13.70	1,190	5188337
	CA*F4961*6D*+TXV	A*VC81005C*B*	36,000	27,400	18.00	13.70	1,210	5188338
	CA*F4961*6D*+TXV	G*VC80604B*B*	36,000	27,400	17.50	13.20	1,220	5188339
CA*F4961*6D*+TXV	G*VC80805C*B*	36,000	27,400	18.00	13.70	1,190	5188340	
CA*F4961*6D*+TXV	G*VC81005C*B*	36,000	27,400	18.00	13.70	1,210	5188341	
CA*F4961*6D*+TXV	ADVC80805C*B*	36,000	27,400	18.00	13.70	1,190	5188385	
CA*F4961*6D*+TXV	ADVC81005C*B*	36,000	27,400	18.00	13.70	1,230	5188422	
CA*F4961*6D*+TXV	G*VC960403BNA*	34,000	25,800	16.50	13.00	1,075	7363989	

See Notes on Page 21.



OUTDOOR UNIT	INDOOR UNITS		COOLING RATINGS				CFM	AHRI #
	COILS/AIR HANDLERS	FURNACES	TOTAL <sup>1</sup>	SENS. <sup>1</sup>	SEER <sup>2</sup>	EER <sup>3</sup>		
ASXC18 0361A* (cont.)	CA*F4961*6D*+TXV	G*VC960603BNA*	34,000	25,800	16.50	13.00	1,075	7363994
	CA*F4961*6D*+TXV	G*VC960803BNA*	34,000	25,800	16.50	13.00	1,100	7363999
	CA*F4961*6D*+TXV	G*VC960804CNA*	34,600	26,200	17.50	13.00	1,190	7364004
	CA*F4961*6D*+TXV	G*VC961005CNA*	34,600	26,200	17.50	13.00	1,175	7364010
	CA*F4961*6D*+TXV	G*VC961205DNA*	34,800	26,400	17.50	13.00	1,150	7364016
	CA*F4961*6D*+TXV	G*VM970603BNA*	34,000	25,800	16.50	13.00	1,075	7364041
	CA*F4961*6D*+TXV	G*VM970803BNA*	34,000	25,800	16.50	13.00	1,100	7364046
	CA*F4961*6D*+TXV	G*VM970804CNA*	34,600	26,200	17.50	13.00	1,190	7364051
	CA*F4961*6D*+TXV	G*VM971005CNA*	34,600	26,200	17.50	13.00	1,175	7364057
	CA*F4961*6D*+TXV	G*VM971205DNA*	34,800	26,400	17.50	13.00	1,150	7364063
	CA*F4961*6D*+TXV	A*VC960403BNA*	34,000	25,800	16.50	13.00	1,075	7364088
	CA*F4961*6D*+TXV	A*VC960603BNA*	34,000	25,800	16.50	13.00	1,075	7364093
	CA*F4961*6D*+TXV	A*VC960803BNA*	34,000	25,800	16.50	13.00	1,100	7364098
	CA*F4961*6D*+TXV	A*VC960804CNA*	34,600	26,200	17.50	13.00	1,190	7364103
	CA*F4961*6D*+TXV	A*VC961005CNA*	34,600	26,200	17.50	13.00	1,175	7364109
	CA*F4961*6D*+TXV	A*VC961205DNA*	34,800	26,400	17.50	13.00	1,150	7364115
	CA*F4961*6D*+TXV	A*VM970603BNA*	34,000	25,800	16.50	13.00	1,075	7364140
	CA*F4961*6D*+TXV	A*VM970803BNA*	34,000	25,800	16.50	13.00	1,100	7364146
	CA*F4961*6D*+TXV	A*VM970804CNA*	34,600	26,200	17.50	13.00	1,190	7364151
	CA*F4961*6D*+TXV	A*VM971005CNA*	34,600	26,200	17.50	13.00	1,175	7364157
	CA*F4961*6D*+TXV	A*VM971205DNA*	34,800	26,400	17.50	13.00	1,150	7364163
	CA*F4961*6D*+TXV	G*EC960603BNA*	35,000	26,600	17.00	13.00	1,150	7368469
	CA*F4961*6D*+TXV	G*EC960803BNA*	35,000	26,600	17.00	12.50	1,150	7368473
	CA*F4961*6D*+TXV	G*EC961004CNA*	35,000	26,600	17.50	13.00	1,150	7368477
	CA*F4961*6D*+TXV	A*EC960603BNA*	35,000	26,600	17.00	13.00	1,150	7368490
	CA*F4961*6D*+TXV	A*EC960803BNA*	35,000	26,600	17.00	12.50	1,150	7368494
	CA*F4961*6D*+TXV	A*EC961004CNA*	35,000	26,600	17.50	13.00	1,150	7368498
	CAPT4961*4A*	G*VC960403BNA*	34,000	25,800	16.50	13.00	1,075	7363990
	CAPT4961*4A*	G*VC960603BNA*	34,000	25,800	16.50	13.00	1,075	7363995
	CAPT4961*4A*	G*VC960803BNA*	34,000	25,800	16.50	13.00	1,100	7364000
	CAPT4961*4A*	G*VC960804CNA*	34,600	26,200	17.00	13.00	1,190	7364005
	CAPT4961*4A*	G*VC961005CNA*	34,600	26,200	17.00	13.00	1,175	7364011
	CAPT4961*4A*	G*VC961205DNA*	34,800	26,400	17.00	13.00	1,150	7364017
	CAPT4961*4A*	G*VM970603BNA*	34,000	25,800	16.50	13.00	1,075	7364042
	CAPT4961*4A*	G*VM970803BNA*	34,000	25,800	16.50	13.00	1,100	7364047
	CAPT4961*4A*	G*VM970804CNA*	34,600	26,200	17.00	13.00	1,190	7364052
	CAPT4961*4A*	G*VM971005CNA*	34,600	26,200	17.00	13.00	1,175	7364058
	CAPT4961*4A*	G*VM971205DNA*	34,800	26,400	17.00	13.00	1,150	7364064
	CAPT4961*4A*	A*VC960403BNA*	34,000	25,800	16.50	13.00	1,075	7364089
	CAPT4961*4A*	A*VC960603BNA*	34,000	25,800	16.50	13.00	1,075	7364094
	CAPT4961*4A*	A*VC960803BNA*	34,000	25,800	16.50	13.00	1,100	7364099
	CAPT4961*4A*	A*VC960804CNA*	34,600	26,200	17.00	13.00	1,190	7364104
	CAPT4961*4A*	A*VC961005CNA*	34,600	26,200	17.00	13.00	1,175	7364110
	CAPT4961*4A*	A*VC961205DNA*	34,800	26,400	17.00	13.00	1,150	7364116
	CAPT4961*4A*	A*VM970603BNA*	34,000	25,800	16.50	13.00	1,075	7364141
	CAPT4961*4A*	A*VM970803BNA*	34,000	25,800	16.50	13.00	1,100	7364147
	CAPT4961*4A*	A*VM970804CNA*	34,600	26,200	17.00	13.00	1,190	7364152
	CAPT4961*4A*	A*VM971005CNA*	34,600	26,200	17.00	13.00	1,175	7364158
CAPT4961*4A*	A*VM971205DNA*	34,800	26,400	17.00	13.00	1,150	7364164	
CAPT4961*4A*	G*EC960603BNA*	35,000	26,600	17.00	13.00	1,150	7368470	
CAPT4961*4A*	G*EC960803BNA*	35,000	26,600	17.00	12.50	1,150	7368474	
CAPT4961*4A*	G*EC961004CNA*	35,000	26,600	17.00	13.00	1,150	7368478	
CAPT4961*4A*	A*EC960603BNA*	35,000	26,600	17.00	13.00	1,150	7368491	
CAPT4961*4A*	A*EC960803BNA*	35,000	26,600	17.00	12.50	1,150	7368495	
CAPT4961*4A*	A*EC961004CNA*	35,000	26,600	17.00	13.00	1,150	7368499	

See Notes on Page 21.

OUTDOOR UNIT	INDOOR UNITS		COOLING RATINGS				CFM	AHRI #
	COILS/AIR HANDLERS	FURNACES	TOTAL <sup>1</sup>	SENS. <sup>1</sup>	SEER <sup>2</sup>	EER <sup>3</sup>		
ASXC18 0361A* (cont.)	CHPF3642C6C*+MBVC1600**-1A*+TXV		35,000	26,600	18.00	13.00	1,250	3610626
	CHPF3642D6C*+MBVC2000**-1A*+TXV		35,000	26,600	18.00	13.00	1,250	3610627
	CHPF3743C6B*+MBVC1600**-1A*+TXV		35,000	26,600	18.00	13.00	1,250	3610628
	CHPF3743C6B*+TXV	A*VC80604B*B*	35,000	26,600	17.00	13.00	1,220	5188342
	CHPF3743C6B*+TXV	A*VC80805C*B*	35,000	26,600	17.00	13.00	1,190	5188343
	CHPF3743C6B*+TXV	A*VC81005C*B*	35,000	26,600	17.00	13.00	1,210	5188344
	CHPF3743C6B*+TXV	G*VC80604B*B*	35,000	26,600	17.00	13.00	1,220	5188345
	CHPF3743C6B*+TXV	G*VC80805C*B*	35,000	26,600	17.00	13.00	1,190	5188346
	CHPF3743C6B*+TXV	G*VC81005C*B*	35,000	26,600	17.00	13.00	1,210	5188347
	CHPF3743C6B*+TXV	G*VC960403BNA*	34,000	25,800	16.50	13.00	1,075	7363991
	CHPF3743C6B*+TXV	G*VC960603BNA*	34,000	25,800	16.50	13.00	1,075	7363996
	CHPF3743C6B*+TXV	G*VC960803BNA*	34,000	25,800	16.50	13.00	1,100	7364001
	CHPF3743C6B*+TXV	G*VC960804CNA*	34,600	26,200	17.00	13.00	1,190	7364006
	CHPF3743C6B*+TXV	G*VC961005CNA*	34,600	26,200	17.00	13.00	1,175	7364012
	CHPF3743C6B*+TXV	G*VM970603BNA*	34,000	25,800	16.50	13.00	1,075	7364043
	CHPF3743C6B*+TXV	G*VM970803BNA*	34,000	25,800	16.50	13.00	1,100	7364048
	CHPF3743C6B*+TXV	G*VM970804CNA*	34,600	26,200	17.00	13.00	1,190	7364053
	CHPF3743C6B*+TXV	G*VM971005CNA*	34,600	26,200	17.00	13.00	1,175	7364059
	CHPF3743C6B*+TXV	A*VC960403BNA*	34,000	25,800	16.50	13.00	1,075	7364090
	CHPF3743C6B*+TXV	A*VC960603BNA*	34,000	25,800	16.50	13.00	1,075	7364095
	CHPF3743C6B*+TXV	A*VC960803BNA*	34,000	25,800	16.50	13.00	1,100	7364100
	CHPF3743C6B*+TXV	A*VC960804CNA*	34,600	26,200	17.00	13.00	1,190	7364105
	CHPF3743C6B*+TXV	A*VC961005CNA*	34,600	26,200	17.00	13.00	1,175	7364111
	CHPF3743C6B*+TXV	A*VM970603BNA*	34,000	25,800	16.50	13.00	1,075	7364142
	CHPF3743C6B*+TXV	A*VM970803BNA*	34,000	25,800	16.50	13.00	1,100	7364148
	CHPF3743C6B*+TXV	A*VM970804CNA*	34,600	26,200	17.00	13.00	1,190	7364153
	CHPF3743C6B*+TXV	A*VM971005CNA*	34,600	26,200	17.00	13.00	1,175	7364159
	CHPF3743C6B*+TXV	G*EC960603BNA*	34,000	25,800	16.50	13.00	1,150	7368471
	CHPF3743C6B*+TXV	G*EC960803BNA*	34,000	25,800	16.50	12.50	1,150	7368475
	CHPF3743C6B*+TXV	G*EC961004CNA*	34,000	25,800	17.00	12.50	1,150	7368479
	CHPF3743C6B*+TXV	A*EC960603BNA*	34,000	25,800	16.50	13.00	1,150	7368492
	CHPF3743C6B*+TXV	A*EC960803BNA*	34,000	25,800	16.50	12.50	1,150	7368496
	CHPF3743C6B*+TXV	A*EC961004CNA*	34,000	25,800	17.00	12.50	1,150	7368500
	CHPF3743D6B*+MBVC2000**-1A*+TXV		35,000	26,600	18.00	13.00	1,250	3610629
	CHPF3743D6B*+TXV	A*VC80604B*B*	35,000	26,600	17.00	13.00	1,220	5188348
	CHPF3743D6B*+TXV	A*VC80805C*B*	35,000	26,600	17.00	13.00	1,190	5188349
	CHPF3743D6B*+TXV	A*VC81005C*B*	35,000	26,600	17.00	13.00	1,210	5188350
	CHPF3743D6B*+TXV	G*VC80604B*B*	35,000	26,600	17.00	13.00	1,220	5188351
	CHPF3743D6B*+TXV	G*VC80805C*B*	35,000	26,600	17.00	13.00	1,190	5188352
	CHPF3743D6B*+TXV	G*VC81005C*B*	35,000	26,600	17.00	13.00	1,210	5188353
	CHPF4860D6D*+EEP+TXV		36,000	27,400	15.00	12.50	1,250	5357239
	CHPF4860D6D*+MBVC2000**-1A*+TXV		35,000	26,600	18.30	13.00	1,250	3610630
	CHPF4860D6D*+TXV	A*VC80604B*B*	36,000	27,400	17.50	13.20	1,220	5188354
	CHPF4860D6D*+TXV	A*VC80805C*B*	36,000	27,400	18.00	13.70	1,190	5188355
	CHPF4860D6D*+TXV	A*VC81005C*B*	36,000	27,400	18.00	13.70	1,210	5188356
	CHPF4860D6D*+TXV	G*VC80604B*B*	36,000	27,400	17.50	13.20	1,220	5188357
	CHPF4860D6D*+TXV	G*VC80805C*B*	36,000	27,400	18.00	13.70	1,190	5188358
	CHPF4860D6D*+TXV	G*VC81005C*B*	36,000	27,400	18.00	13.70	1,210	5188359
	CHPF4860D6D*+TXV	G*VC960804CNA*	34,600	26,200	17.50	13.00	1,190	7364007
	CHPF4860D6D*+TXV	G*VC961005CNA*	34,600	26,200	17.50	13.00	1,175	7364013
CHPF4860D6D*+TXV	G*VC961205DNA*	34,800	26,400	17.50	13.00	1,150	7364018	
CHPF4860D6D*+TXV	G*VM970804CNA*	34,600	26,200	17.50	13.00	1,190	7364054	
CHPF4860D6D*+TXV	G*VM971005CNA*	34,600	26,200	17.50	13.00	1,175	7364060	
CHPF4860D6D*+TXV	G*VM971205DNA*	34,800	26,400	17.50	13.00	1,150	7364065	
CHPF4860D6D*+TXV	A*VC960804CNA*	34,600	26,200	17.50	13.00	1,190	7364106	

See Notes on Page 21.

OUTDOOR UNIT	INDOOR UNITS		COOLING RATINGS				CFM	AHRI #
	COILS/AIR HANDLERS	FURNACES	TOTAL <sup>1</sup>	SENS. <sup>1</sup>	SEER <sup>2</sup>	EER <sup>3</sup>		
ASXC18 0361A* (cont.)	CHPF4860D6D*+TXV	A*VC961005CNA*	34,600	26,200	17.50	13.00	1,175	7364112
	CHPF4860D6D*+TXV	A*VC961205DNA*	34,800	26,400	17.50	13.00	1,150	7364117
	CHPF4860D6D*+TXV	A*VM970804CNA*	34,600	26,200	17.50	13.00	1,190	7364154
	CHPF4860D6D*+TXV	A*VM971005CNA*	34,600	26,200	17.50	13.00	1,175	7364160
	CHPF4860D6D*+TXV	A*VM971205DNA*	34,800	26,400	17.50	13.00	1,150	7364165
	CSCF3642N6D*+TXV	G*VC960403BNA*	34,000	25,800	16.50	13.00	1,075	7363992
	CSCF3642N6D*+TXV	G*VC960603BNA*	34,000	25,800	16.50	13.00	1,075	7363997
	CSCF3642N6D*+TXV	G*VC960803BNA*	34,000	25,800	16.50	13.00	1,100	7364002
	CSCF3642N6D*+TXV	G*VC960804CNA*	34,400	26,200	17.00	13.00	1,190	7364008
	CSCF3642N6D*+TXV	G*VC961005CNA*	34,400	26,200	17.00	13.00	1,175	7364014
	CSCF3642N6D*+TXV	G*VM970603BNA*	34,000	25,800	16.50	13.00	1,075	7364044
	CSCF3642N6D*+TXV	G*VM970803BNA*	34,000	25,800	16.50	13.00	1,100	7364049
	CSCF3642N6D*+TXV	G*VM970804CNA*	34,400	26,200	17.00	13.00	1,190	7364055
	CSCF3642N6D*+TXV	G*VM971005CNA*	34,400	26,200	17.00	13.00	1,175	7364061
	CSCF3642N6D*+TXV	A*VC960403BNA*	34,000	25,800	16.50	13.00	1,075	7364091
	CSCF3642N6D*+TXV	A*VC960603BNA*	34,000	25,800	16.50	13.00	1,075	7364096
	CSCF3642N6D*+TXV	A*VC960803BNA*	34,000	25,800	16.50	13.00	1,100	7364101
	CSCF3642N6D*+TXV	A*VC960804CNA*	34,400	26,200	17.00	13.00	1,190	7364107
	CSCF3642N6D*+TXV	A*VC961005CNA*	34,400	26,200	17.00	13.00	1,175	7364113
	CSCF3642N6D*+TXV	A*VM970603BNA*	34,000	25,800	16.50	13.00	1,075	7364143
	CSCF3642N6D*+TXV	A*VM970803BNA*	34,000	25,800	16.50	13.00	1,100	7364149
	CSCF3642N6D*+TXV	A*VM970804CNA*	34,400	26,200	17.00	13.00	1,190	7364155
	CSCF3642N6D*+TXV	A*VM971005CNA*	34,400	26,200	17.00	13.00	1,175	7364161
	CSCF4860N6D*+EEP+TXV		36,000	27,400	15.00	12.50	1,250	5357240
CSCF4860N6D*+TXV	G*VC961205DNA*	34,600	26,200	17.00	13.00	1,150	7364019	
CSCF4860N6D*+TXV	G*VM971205DNA*	34,600	26,200	17.00	13.00	1,150	7364066	
CSCF4860N6D*+TXV	A*VC961205DNA*	34,600	26,200	17.00	13.00	1,150	7364118	
CSCF4860N6D*+TXV	A*VM971205DNA*	34,600	26,200	17.00	13.00	1,150	7364166	
ASXC18 0481A*	AVPTC48C14A*		45,000	34,200	16.00	12.00	1,450	7080499
	AVPTC48D14A*		47,000	35,800	17.50	13.00	1,700	5924395
	CA*F4860*6D*+EEP+TXV		47,000	35,800	15.00	12.00	1,500	5614885
	CA*F4961*6D*+EEP+TXV		48,000	36,400	15.50	12.50	1,500	5357241
	CA*F4961*6D*+MBVC1600**-1A*+TXV		46,000	35,000	17.00	13.00	1,725	6498354
	CA*F4961*6D*+MBVC2000**-1A*+TXV		47,500	36,200	18.00	13.25	1,750	4431459
	CA*F4961*6D*+TXV	A*VC80805C*B*	48,000	36,400	17.00	12.80	1,590	5188360
	CA*F4961*6D*+TXV	A*VC81005C*B*	48,000	36,400	17.00	12.20	1,520	5188361
	CA*F4961*6D*+TXV	G*VC80805C*B*	48,000	36,400	17.00	12.80	1,590	5188362
	CA*F4961*6D*+TXV	G*VC81005C*B*	48,000	36,400	17.00	12.20	1,520	5188363
	CA*F4961*6D*+TXV	ADVC80805C*B*	48,000	36,400	17.00	12.80	1,580	5188401
	CA*F4961*6D*+TXV	ADVC81005C*B*	48,000	36,400	17.00	12.20	1,550	5188441
	CA*F4961*6D*+TXV	G*VC960804CNA*	45,500	34,600	17.00	12.80	1,525	7364020
	CA*F4961*6D*+TXV	G*VC961005CNA*	45,500	34,600	17.00	12.80	1,520	7364024
	CA*F4961*6D*+TXV	G*VC961205DNA*	46,000	35,000	17.50	12.80	1,530	7364028
	CA*F4961*6D*+TXV	G*VM970804CNA*	45,500	34,600	17.00	12.80	1,525	7364067
	CA*F4961*6D*+TXV	G*VM971005CNA*	45,500	34,600	17.00	12.80	1,520	7364071
	CA*F4961*6D*+TXV	G*VM971205DNA*	46,000	35,000	17.50	12.80	1,530	7364075
	CA*F4961*6D*+TXV	A*VC960804CNA*	45,500	34,600	17.00	12.80	1,525	7364119
	CA*F4961*6D*+TXV	A*VC961005CNA*	45,500	34,600	17.00	12.80	1,520	7364123
	CA*F4961*6D*+TXV	A*VC961205DNA*	46,000	35,000	17.50	12.80	1,530	7364127
	CA*F4961*6D*+TXV	A*VM970804CNA*	45,500	34,600	17.00	12.80	1,525	7364167
	CA*F4961*6D*+TXV	A*VM971005CNA*	45,500	34,600	17.00	12.80	1,520	7364171
	CA*F4961*6D*+TXV	A*VM971205DNA*	46,000	35,000	17.50	12.80	1,530	7364176
CA*F4961*6D*+TXV	G*EC961004CNA*	45,500	34,600	17.00	13.00	1,550	7368480	
CA*F4961*6D*+TXV	G*EC961205DNA*	45,500	34,600	17.00	13.00	1,550	7368483	

See Notes on Page 21.

OUTDOOR UNIT	INDOOR UNITS		COOLING RATINGS				CFM	AHRI #	
	COILS/AIR HANDLERS	FURNACES	TOTAL <sup>1</sup>	SENS. <sup>1</sup>	SEER <sup>2</sup>	EER <sup>3</sup>			
ASXC18 0481A* (cont.)	CA*F4961*6D*+TXV	A*EC961004CNA*	45,500	34,600	17.00	13.00	1,550	7368501	
	CA*F4961*6D*+TXV	A*EC961205DNA*	45,500	34,600	17.00	13.00	1,550	7368504	
	CAPT4961*4A*	G*VC960804CNA*	45,500	34,600	17.00	12.80	1,525	7364021	
	CAPT4961*4A*	G*VC961005CNA*	45,500	34,600	17.00	12.80	1,520	7364025	
	CAPT4961*4A*	G*VC961205DNA*	46,000	35,000	17.50	12.80	1,530	7364029	
	CAPT4961*4A*	G*VM970804CNA*	45,500	34,600	17.00	12.80	1,525	7364068	
	CAPT4961*4A*	G*VM971005CNA*	45,500	34,600	17.00	12.80	1,520	7364072	
	CAPT4961*4A*	G*VM971205DNA*	46,000	35,000	17.50	12.80	1,530	7364076	
	CAPT4961*4A*	A*VC960804CNA*	45,500	34,600	17.00	12.80	1,525	7364120	
	CAPT4961*4A*	A*VC961005CNA*	45,500	34,600	17.00	12.80	1,520	7364124	
	CAPT4961*4A*	A*VC961205DNA*	46,000	35,000	17.50	12.80	1,530	7364128	
	CAPT4961*4A*	A*VM970804CNA*	45,500	34,600	17.00	12.80	1,525	7364168	
	CAPT4961*4A*	A*VM971005CNA*	45,500	34,600	17.00	12.80	1,520	7364172	
	CAPT4961*4A*	A*VM971205DNA*	46,000	35,000	17.50	12.80	1,530	7364177	
	CAPT4961*4A*	G*EC961004CNA*	45,500	34,600	17.00	13.00	1,550	7368481	
	CAPT4961*4A*	G*EC961205DNA*	45,500	34,600	17.00	13.00	1,550	7368484	
	CAPT4961*4A*	A*EC961004CNA*	45,500	34,600	17.00	13.00	1,550	7368502	
	CAPT4961*4A*	A*EC961205DNA*	45,500	34,600	17.00	13.00	1,550	7368505	
	CHPF4860D6D*+EEP+TXV			48,000	36,400	15.50	12.50	1,500	5357242
	CHPF4860D6D*+MBVC1600**-1A*+TXV			46,000	35,000	17.00	13.00	1,725	3610641
	CHPF4860D6D*+MBVC2000**-1A*+TXV			47,500	36,200	18.00	13.25	1,750	3610642
	CHPF4860D6D*+TXV	A*VC80805C*B*		48,000	36,400	17.00	12.80	1,590	5188364
	CHPF4860D6D*+TXV	A*VC81005C*B*		48,000	36,400	17.00	12.20	1,520	5188365
	CHPF4860D6D*+TXV	G*VC80805C*B*		48,000	36,400	17.00	12.80	1,590	5188366
	CHPF4860D6D*+TXV	G*VC81005C*B*		48,000	36,400	17.00	12.20	1,520	5188367
	CHPF4860D6D*+TXV	G*VC960804CNA*		45,500	34,600	17.00	12.80	1,525	7364022
	CHPF4860D6D*+TXV	G*VC961005CNA*		45,500	34,600	17.00	12.80	1,520	7364026
	CHPF4860D6D*+TXV	G*VC961205DNA*		46,000	35,000	17.50	12.80	1,530	7364030
	CHPF4860D6D*+TXV	G*VM970804CNA*		45,500	34,600	17.00	12.80	1,525	7364069
	CHPF4860D6D*+TXV	G*VM971005CNA*		45,500	34,600	17.00	12.80	1,520	7364073
	CHPF4860D6D*+TXV	G*VM971205DNA*		46,000	35,000	17.50	12.80	1,530	7364077
	CHPF4860D6D*+TXV	A*VC960804CNA*		45,500	34,600	17.00	12.80	1,525	7364121
	CHPF4860D6D*+TXV	A*VC961005CNA*		45,500	34,600	17.00	12.80	1,520	7364125
	CHPF4860D6D*+TXV	A*VC961205DNA*		46,000	35,000	17.50	12.80	1,530	7364129
	CHPF4860D6D*+TXV	A*VM970804CNA*		45,500	34,600	17.00	12.80	1,525	7364169
	CHPF4860D6D*+TXV	A*VM971005CNA*		45,500	34,600	17.00	12.80	1,520	7364173
	CHPF4860D6D*+TXV	A*VM971205DNA*		46,000	35,000	17.50	12.80	1,530	7364178
	CHPF4860D6D*+TXV	G*EC961004CNA*		45,500	34,600	17.00	13.00	1,550	7368482
	CHPF4860D6D*+TXV	G*EC961205DNA*		45,500	34,600	17.00	13.00	1,550	7368485
	CHPF4860D6D*+TXV	A*EC961004CNA*		45,500	34,600	17.00	13.00	1,550	7368503
	CHPF4860D6D*+TXV	A*EC961205DNA*		45,500	34,600	17.00	13.00	1,550	7368506
	CSCF4860N6D*+EEP+TXV			48,000	36,400	15.50	12.50	1,500	5357243
	CSCF4860N6D*+TXV	G*VC960804CNA*		45,000	34,200	16.50	12.80	1,525	7364023
	CSCF4860N6D*+TXV	G*VC961005CNA*		45,000	34,200	16.50	12.80	1,520	7364027
	CSCF4860N6D*+TXV	G*VC961205DNA*		45,500	34,600	17.00	12.80	1,530	7364031
CSCF4860N6D*+TXV	G*VM970804CNA*		45,000	34,200	16.50	12.80	1,525	7364070	
CSCF4860N6D*+TXV	G*VM971005CNA*		45,000	34,200	16.50	12.80	1,520	7364074	
CSCF4860N6D*+TXV	G*VM971205DNA*		45,500	34,600	17.00	12.80	1,530	7364078	
CSCF4860N6D*+TXV	A*VC960804CNA*		45,000	34,200	16.50	12.80	1,525	7364122	
CSCF4860N6D*+TXV	A*VC961005CNA*		45,000	34,200	16.50	12.80	1,520	7364126	
CSCF4860N6D*+TXV	A*VC961205DNA*		45,500	34,600	17.00	12.80	1,530	7364130	
CSCF4860N6D*+TXV	A*VM970804CNA*		45,000	34,200	16.50	12.80	1,525	7364170	
CSCF4860N6D*+TXV	A*VM971005CNA*		45,000	34,200	16.50	12.80	1,520	7364174	
CSCF4860N6D*+TXV	A*VM971205DNA*		45,500	34,600	17.00	12.80	1,530	7364179	

See Notes on Page 21.

OUTDOOR UNIT	INDOOR UNITS		COOLING RATINGS				CFM	AHRI #
	COILS/AIR HANDLERS	FURNACES	TOTAL <sup>1</sup>	SENS. <sup>1</sup>	SEER <sup>2</sup>	EER <sup>3</sup>		
ASXC18 0601A*	AVPTC60D14A*		58,000	42,000	16.00	11.75	1,780	5924396
	CA*F4961*6D*+EEP+TXV		57,000	41,000	15.00	12.00	1,500	5357244
	CA*F4961*6D*+MBVC2000**-1A*+TXV		58,000	42,000	17.00	12.00	2,000	4431460
	CA*F4961*6D*+TXV	G*VC961005CNA*	56,000	40,500	15.50	11.80	1,750	7364032
	CA*F4961*6D*+TXV	G*VC961205DNA*	56,000	40,500	16.00	11.80	1,600	7364036
	CA*F4961*6D*+TXV	G*VM971005CNA*	56,000	40,500	15.50	11.80	1,750	7364079
	CA*F4961*6D*+TXV	G*VM971205DNA*	56,000	40,500	16.00	11.80	1,600	7364083
	CA*F4961*6D*+TXV	A*VC961005CNA*	56,000	40,500	15.50	11.80	1,750	7364131
	CA*F4961*6D*+TXV	A*VC961205DNA*	56,000	40,500	16.00	11.80	1,600	7364135
	CA*F4961*6D*+TXV	A*VM971005CNA*	56,000	40,500	15.50	11.80	1,750	7364180
	CA*F4961*6D*+TXV	A*VM971205DNA*	56,000	40,500	16.00	11.80	1,600	7364184
	CAPT4961*4A*	G*VC961005CNA*	56,000	40,500	15.50	11.80	1,750	7364033
	CAPT4961*4A*	G*VC961205DNA*	56,000	40,500	16.00	11.80	1,600	7364037
	CAPT4961*4A*	G*VM971005CNA*	56,000	40,500	15.50	11.80	1,750	7364080
	CAPT4961*4A*	G*VM971205DNA*	56,000	40,500	16.00	11.80	1,600	7364084
	CAPT4961*4A*	A*VC961005CNA*	56,000	40,500	15.50	11.80	1,750	7364132
	CAPT4961*4A*	A*VC961205DNA*	56,000	40,500	16.00	11.80	1,600	7364136
	CAPT4961*4A*	A*VM971005CNA*	56,000	40,500	15.50	11.80	1,750	7364181
	CAPT4961*4A*	A*VM971205DNA*	56,000	40,500	16.00	11.80	1,600	7364185
	CHPF4860D6D*+EEP+TXV		57,000	41,000	15.00	12.00	1,500	5357245
	CHPF4860D6D*+MBVC2000**-1A*+TXV		58,000	42,000	17.00	12.00	2,000	3610647
	CHPF4860D6D*+TXV	G*VC961005CNA*	56,000	40,500	15.50	11.80	1,750	7364034
	CHPF4860D6D*+TXV	G*VC961205DNA*	56,000	40,500	16.00	11.80	1,600	7364038
	CHPF4860D6D*+TXV	G*VM971005CNA*	56,000	40,500	15.50	11.80	1,750	7364081
	CHPF4860D6D*+TXV	G*VM971205DNA*	56,000	40,500	16.00	11.80	1,600	7364085
	CHPF4860D6D*+TXV	A*VC961005CNA*	56,000	40,500	15.50	11.80	1,750	7364133
	CHPF4860D6D*+TXV	A*VC961205DNA*	56,000	40,500	16.00	11.80	1,600	7364137
	CHPF4860D6D*+TXV	A*VM971005CNA*	56,000	40,500	15.50	11.80	1,750	7364182
	CHPF4860D6D*+TXV	A*VM971205DNA*	56,000	40,500	16.00	11.80	1,600	7364186
	CSCF4860N6D*+EEP+TXV		57,000	41,000	15.00	12.00	1,500	5357246
	CSCF4860N6D*+TXV	G*VC961005CNA*	56,000	40,500	15.50	11.80	1,750	7364035
	CSCF4860N6D*+TXV	G*VC961205DNA*	55,500	40,000	15.50	11.80	1,600	7364039
	CSCF4860N6D*+TXV	G*VM971005CNA*	56,000	40,500	15.50	11.80	1,750	7364082
	CSCF4860N6D*+TXV	G*VM971205DNA*	55,500	40,000	15.50	11.80	1,600	7364086
	CSCF4860N6D*+TXV	A*VC961005CNA*	56,000	40,500	15.50	11.80	1,750	7364134
	CSCF4860N6D*+TXV	A*VC961205DNA*	55,500	40,000	15.50	11.80	1,600	7364138
	CSCF4860N6D*+TXV	A*VM971005CNA*	56,000	40,500	15.50	11.80	1,750	7364183
	CSCF4860N6D*+TXV	A*VM971205DNA*	55,500	40,000	15.50	11.80	1,600	7364187

<sup>1</sup> BTU/h

<sup>2</sup> Seasonal Energy Efficiency Ratio; Certified per AHRI 210/240 @ 80°F/ 67°F/ 95°F

<sup>3</sup> Energy Efficiency Ratio @ 80°F/ 67°F/ 95°F

**NOTES**

- Always check the S&R plate for electrical data on the unit being installed.
- When matching the outdoor unit to the indoor unit, use the piston supplied with the outdoor unit or that specified on the piston kit chart supplied with the indoor unit.
- EEP - Order from Service Dept. Part No. B13707-38 or new Solid State Board B13707-35S. Part No. B13707-38 is not interchangeable with B13707-35S. The Goodman Gas Furnace contains the EEP cooling time delay

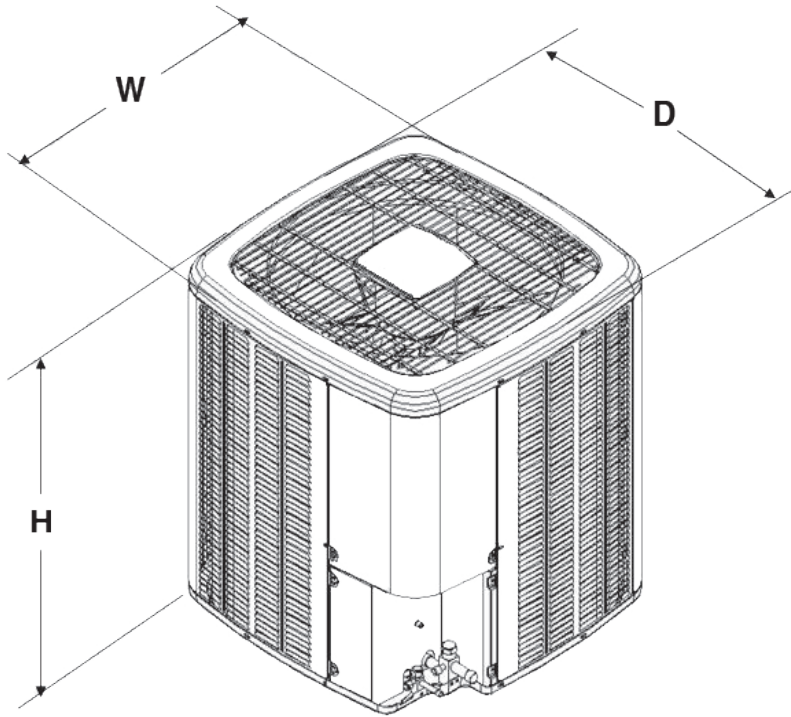

MODEL	W	D	H
ASXC180361A*	35½	35½	38¼
ASXC180481A*	35½	35½	38¼
ASXC180601A*	35½	35½	38¼

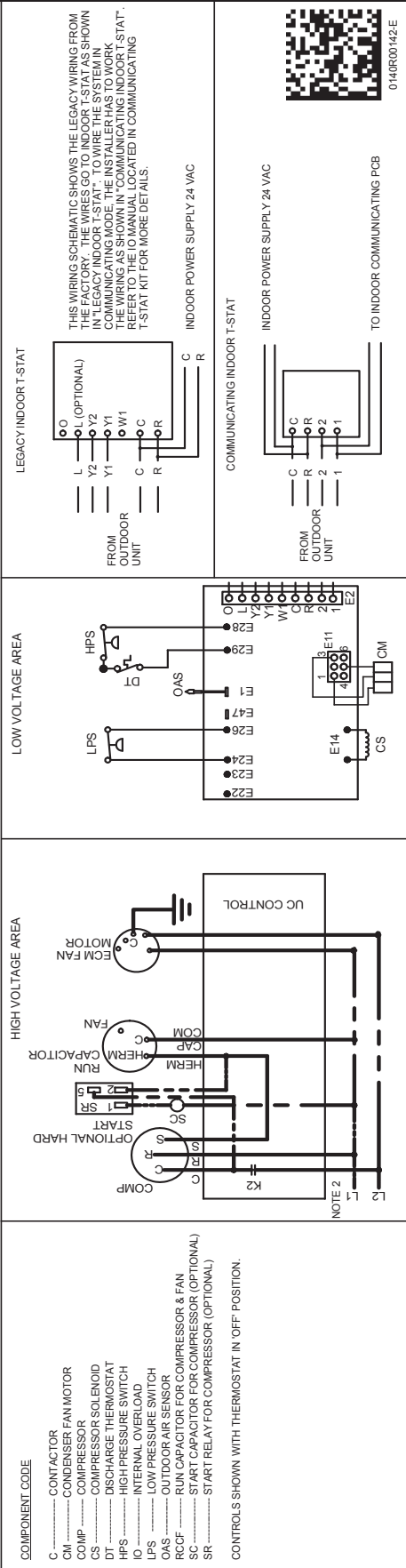
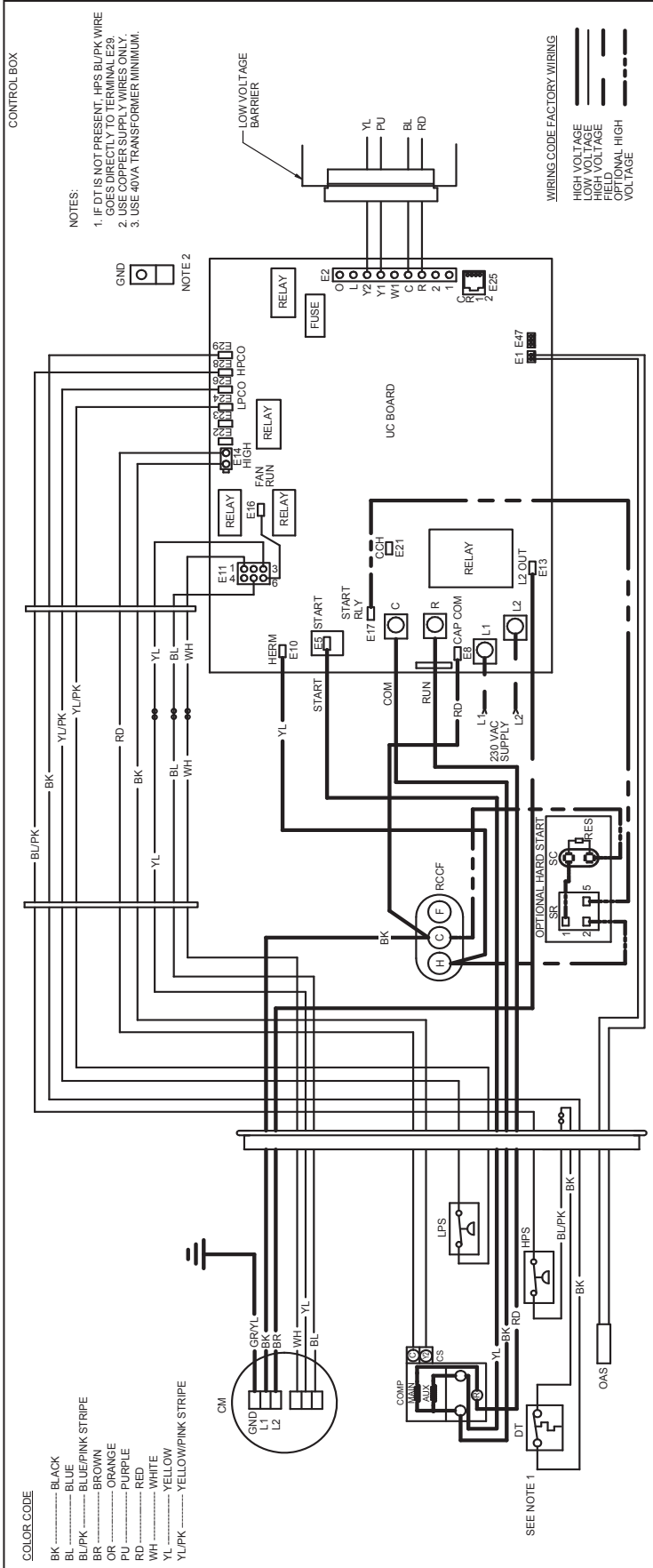

**WARNING** High Voltage: Disconnect all power before servicing or installing this unit. Multiple power sources may be present. Failure to do so may cause property damage, personal injury, or death.

MODEL	DESCRIPTION	ASXC18 036	ASXC18 048	ASXC18 060
ABK-20	Anchor Bracket Kit <sup>0</sup>	X	X	X
ASC-01	Anti-Short Cycle Kit	X	X	X
B1141643 <sup>1</sup>	24V Transformer	X	X	X
CSR-U-1	Hard-start Kit	X	X	
CSR-U-2	Hard-start Kit			
CSR-U-3	Hard-start Kit			X
FSK01A <sup>2</sup>	Freeze Protection Kit	X	X	X
LSK02A	Liquid Line Solenoid Valve	X	X	X
OT18-60A <sup>3</sup>	Outdoor Thermostat/Lockout Thermostat	X	X	X
TX3N4	TXV Kit	X		
TX5N4	TXV Kit		X	X

<sup>0</sup> Contains 20 brackets; four brackets needed to anchor unit to pad

<sup>1</sup> This component is included in the CTK01AA communicating thermostat kit.

<sup>2</sup> Installed on indoor coil

<sup>3</sup> Available in 24V legacy mode only. This feature is integrated in the communicating mode.

Note: Maximum number of installed accessories at the same time is limited by the size of the unit's control box.