

## Sample (printed text shown on rendering of die-cut card)

### To set time and day

- 1 Press SET CLOCK/DAY/SCHEDULE\*
- 2 Press ▲/▼ to set time
- 3 Press SET DAY
- 4 Press ▲/▼ to select day \* If this option is not displayed, press
- 5 Press DONE to save & exit DONE, RUN SCHEDULE or CANCEL

### To set program schedule

- 1 Press SYSTEM to select Heat or Cool
- 2 Press SET CLOCK/DAY/SCHEDULE\*
- 3 Press SET SCHEDULE
- 4 Press ▲/▼ to set Mon-Fri Wake time, then press NEXT
- 5 Press ▲/▼ to set Mon-Fri Wake temperature, then press NEXT
- 6 Repeat steps 4-5 to set Leave/Return/Sleep time periods
- 7 Repeat steps 4-5 to set Sat-Sun time periods
- 8 Press DONE to save & exit

### To override program schedule

- Press ▲/▼ to change temp for this time period only
- Press HOLD, ▲/▼ to change temp for all time periods
- Press RUN SCHEDULE or CANCEL to resume schedule

Copyright © 2007  
Honeywell International Inc.  
All rights reserved.  
M.S. Rev. 10-07



69-1778ES-02

## Actual (printable text & graphics)

### To set time and day

- 1 Press SET CLOCK/DAY/SCHEDULE\*
- 2 Press ▲/▼ to set time
- 3 Press SET DAY
- 4 Press ▲/▼ to select day \* If this option is not displayed, press
- 5 Press DONE to save & exit DONE, RUN SCHEDULE or CANCEL

### To set program schedule

- 1 Press SYSTEM to select Heat or Cool
- 2 Press SET CLOCK/DAY/SCHEDULE\*
- 3 Press SET SCHEDULE
- 4 Press ▲/▼ to set Mon-Fri Wake time, then press NEXT
- 5 Press ▲/▼ to set Mon-Fri Wake temperature, then press NEXT
- 6 Repeat steps 4-5 to set Leave/Return/Sleep time periods
- 7 Repeat steps 4-5 to set Sat-Sun time periods
- 8 Press DONE to save & exit

### To override program schedule

- Press ▲/▼ to change temp for this time period only
- Press HOLD, ▲/▼ to change temp for all time periods
- Press RUN SCHEDULE or CANCEL to resume schedule

Copyright © 2007  
Honeywell International Inc.  
All rights reserved.  
M.S. Rev. 10-07



69-1778ES-02

### Para ajustar el día y la hora

- 1 Oprima SET CLOCK/DAY/SCHEDULE\*
- 2 Oprima ▲/▼ para ajustar la hora
- 3 Oprima SET DAY
- 4 Oprima ▲/▼ para ajustar el día \* Si esta opción no aparece oprima
- 5 Oprima DONE para salir DONE, RUN SCHEDULE o CANCEL

### Para fijar el programa de horarios

- 1 Oprima SYSTEM para seleccionar Heat o Cool
- 2 Oprima SET CLOCK/DAY/SCHEDULE\*
- 3 Oprima SET SCHEDULE
- 4 Oprima ▲/▼ para ajustar la hora de Wake Mon-Fri, y oprima NEXT
- 5 Oprima ▲/▼ para ajustar la temp. de Wake Mon-Fri, y oprima NEXT
- 6 Repita los pasos 4-5 para fijar los períodos Leave/Return/Sleep
- 7 Repita los pasos 4-5 para fijar los períodos Sat-Sun (fin de semana)
- 8 Oprima DONE para salir

### Para anular el programa de horarios

- Oprima ▲/▼ para cambiar temp. para este período
- Oprima HOLD, ▲/▼ para cambiar temp. para todos los períodos
- Oprima RUN SCHEDULE o CANCEL para seguir con el horario

Copyright © 2007  
Honeywell International Inc.  
Todos los  
derechos reservados.  
M.S. Rev. 10-07



69-1778ES-02

### Para ajustar el día y la hora

- 1 Oprima SET CLOCK/DAY/SCHEDULE\*
- 2 Oprima ▲/▼ para ajustar la hora
- 3 Oprima SET DAY
- 4 Oprima ▲/▼ para ajustar el día \* Si esta opción no aparece oprima
- 5 Oprima DONE para salir DONE, RUN SCHEDULE o CANCEL

### Para fijar el programa de horarios

- 1 Oprima SYSTEM para seleccionar Heat o Cool
- 2 Oprima SET CLOCK/DAY/SCHEDULE\*
- 3 Oprima SET SCHEDULE
- 4 Oprima ▲/▼ para ajustar la hora de Wake Mon-Fri, y oprima NEXT
- 5 Oprima ▲/▼ para ajustar la temp. de Wake Mon-Fri, y oprima NEXT
- 6 Repita los pasos 4-5 para fijar los períodos Leave/Return/Sleep
- 7 Repita los pasos 4-5 para fijar los períodos Sat-Sun (fin de semana)
- 8 Oprima DONE para salir

### Para anular el programa de horarios

- Oprima ▲/▼ para cambiar temp. para este período
- Oprima HOLD, ▲/▼ para cambiar temp. para todos los períodos
- Oprima RUN SCHEDULE o CANCEL para seguir con el horario

Copyright © 2007  
Honeywell International Inc.  
Todos los  
derechos reservados.  
M.S. Rev. 10-07



69-1778ES-02

## NOTES TO PRINTER

Print front and back (above) on 80# Sterling Ultra Gloss Cover stock.

See enclosed PDF for precise shape & dimensions of die cut.

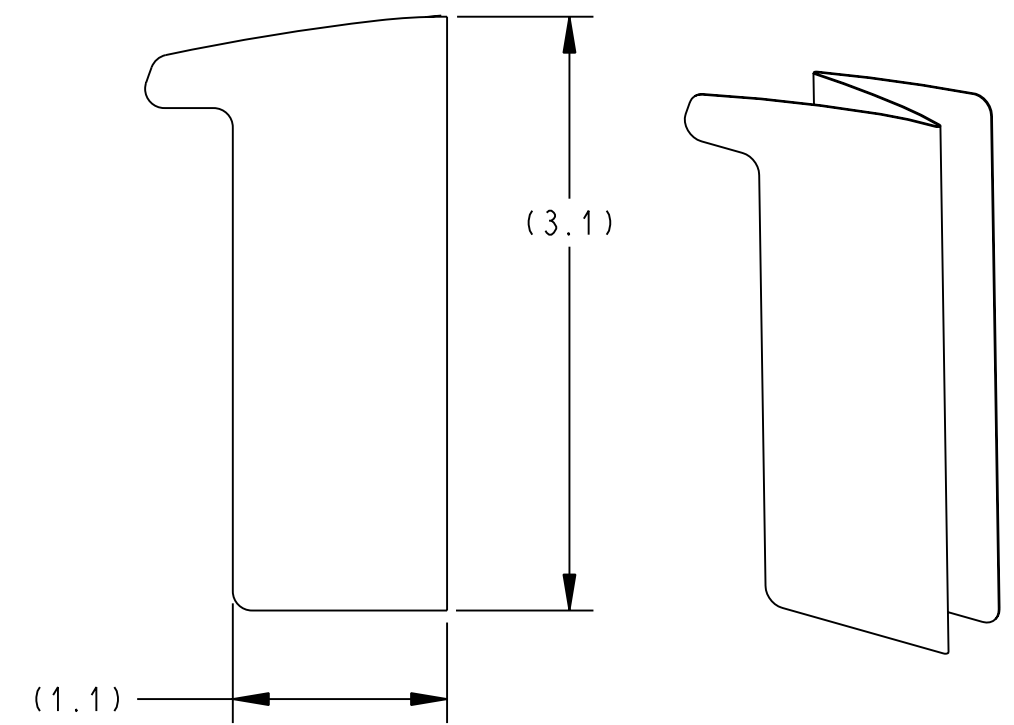
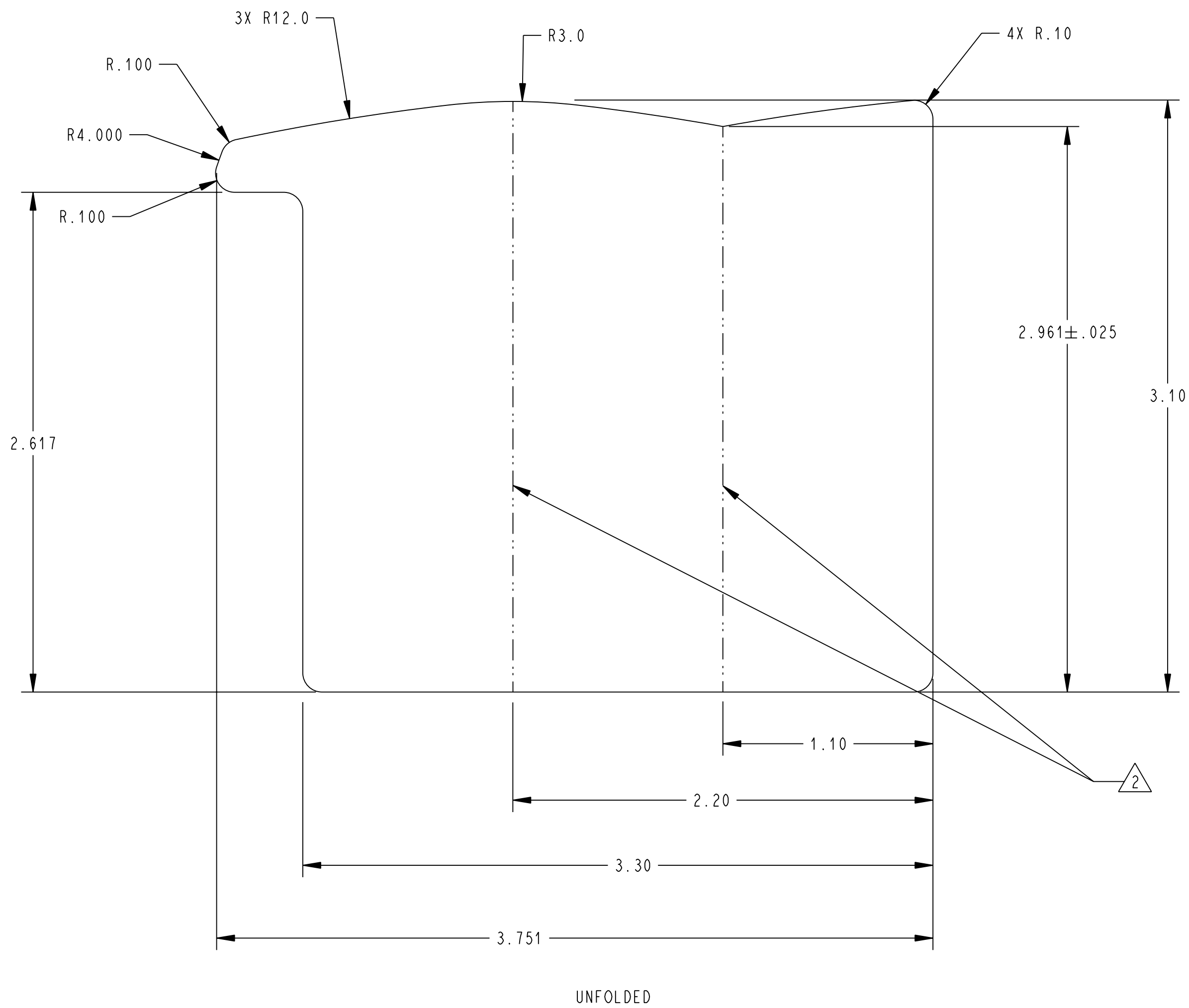

REFERENCE VIEWS  
 SCALE 1:1 3

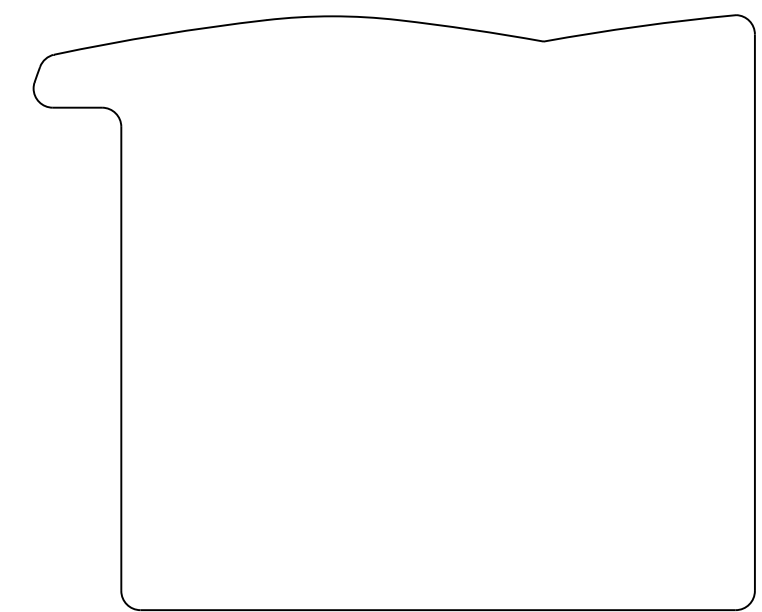

REFERENCE VIEW  
 SCALE 1:1 2

1 MATERIAL: 80# STERLING ULTRA GLOSS COVER.

2 FOLD LINES: SCORE FOLD HERE.

3 PARTS TO BE DELIVERED FLAT. SCORE TO ALLOW FOLDING AS SHOWN HERE.

4. DIMENSIONS ARE IN INCHES.